

Spill Containment

Contents

IBC Bund, Spill Pallet or Sump Pallets	2-12
IBC Spill Containment Bunds - User Healthy & Safety Instructions	13-14
Spill Trays, Drum Bunds & Drum Pallets	15-22
Tank Bunds	23-25
Standard Sized Bunds	26
Custom Built Bunds and Spill Trays	27-28

The information contained in this brochure is for general information purposes only. The information is provided by Sui Generis International Ltd and whilst every effort has been made to ensure the information was correct at the time of publication, we make no representations or warranties of any kind, express or implied, about the completeness, accuracy, reliability, suitability or availability with respect to the information, products, services, or related graphics contained within the brochure for any purpose. Any reliance you place on such information is therefore strictly at your own risk.

Sui Generis International Ltd.

The Chandler's Centre
Hythe Quay
Colchester
CO2 8JF
Tel: 01206 798 798
Fax: 01206 866 666
Email: info@sui generis.co.uk
www.sui generis.co.uk

Fibreglass Linings
Industrial Coatings
Surface Preparation
Spill Containment

Fibreglass Mouldings
Anti-slip Stair Covers
Anti-slip Floor Sheets
Fibreglass Grating

Spill Containment

IBC Bund, Spill Pallet or Sump Pallet - SG101

£520 FREE delivery. Quantity discounts available.

Spill containment for 1 x 1000 litre IBC. Without dispensing facility.

Designed for the long term safe bunding of IBC's and suitable for all oils and 95% of chemicals, IBC Bund Spill Pallets help you comply with current oil and chemical storage regulations.

Why buy Sui Generis IBC Bund Spill Pallets?

Tough reinforced composite construction.
Broad range chemical compatibility.
Retains long term structural integrity.
Lighter than steel or polyethylene for easy manual handling.
Simply shaped for easy cleaning.
Order and bund your next IBC sooner with a UDL of 2000 kgs.
Large catchment area around IBC to contain leaks.
10 Year Guarantee.

Benefits:

Protects the workplace, environment and personnel.
Designed for most sizes of IBC.
Maintenance free.

Compliance:

Compliant with the 110% bund regulations.
No taps or drainage points to compromise the bund area.

10 Year Guarantee

As the UK manufacturer we offer quality products at competitive prices. Should you receive a more competitive like for like quotation, we guarantee to beat it.

To order call: 01206 798 798

All prices exclude VAT. FREE delivery prices are to anywhere in England, Scotland and Wales. Orders placed before midday will usually be despatched the following day. Usual delivery 2-3 days.



SG101

Principal Material:	GRP (Glass Reinforced Plastic)
External Dimensions:	1670 x 1570 x 650 mm
Regulation Capacity:	1100 litres
Actual Capacity:	1100+ litres
Maximum UDL:	2000 kgs
Weight:	Circa 45 kgs
Maximum size of IBC:	1270 length x 1100 width mm
Minimum size of IBC:	1110 length x 950 width mm
	Extended sizes available.
Standard Colour:	RAL 5015 Blue
Forklift Facility:	Available at an additional cost of £150.00 and extended delivery time.

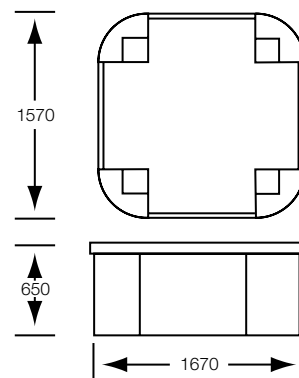

Sui Generis International Ltd.

The Chandler's Centre
Hythe Quay
Colchester
CO2 8JF
Tel: 01206 798 798
Fax: 01206 866 666
Email: info@sui generis.co.uk
www.sui generis.co.uk

Fibreglass Linings
Industrial Coatings
Surface Preparation
Spill Containment

Fibreglass Mouldings
Anti-slip Stair Covers
Anti-slip Floor Sheets
Fibreglass Grating

Spill Containment

IBC Bund, Spill Pallet or Sump Pallet - SG102

£525 FREE delivery. Quantity discounts available.

Spill containment for 1 x 1000 litre IBC. With dispensing facility.

Designed for the long term safe bunding of IBC's and suitable for all oils and 95% of chemicals, IBC Bund Spill Pallets help you comply with current oil and chemical storage regulations.

With unique drip tray feature

Specially designed for easy cleaning, the drip tray feature developed by Sui Generis is unique to our Bund Spill Pallet. The tray catches leaks and small spills during dispensing operations in an easy to reach area, meaning you don't have to clean the entire bund floor.

Why buy Sui Generis IBC Bund Spill Pallets?

- Tough reinforced composite construction.
- Broad range chemical compatibility.
- Retains long term structural integrity.
- Lighter than steel or polyethylene for easy manual handling.
- Simply shaped for easy cleaning.
- Order and bund your next IBC sooner with a UDL of 2000 kgs.
- Low sides to ease the manual handling of dispensed liquids.
- Large catchment area around IBC to contain leaks.
- 10 Year Guarantee.

Benefits:

- Protects the workplace, environment and personnel.
- Designed for most sizes of IBC.
- Maintenance free.

Compliance:

- Compliant with the 110% bund regulations.
- No taps or drainage points to compromise the bund area.

10 Year Guarantee



SG102

Principal Material:	GRP (Glass Reinforced Plastic)
External Dimensions:	1930 x 1570 x 650 mm
Regulation Capacity:	1100 litres
Actual Capacity:	1100+ litres
Maximum UDL:	2000 kgs
Weight:	Circa 45 kgs
Maximum size of IBC:	1270 length x 1100 width mm
Minimum size of IBC:	1110 length x 950 width mm
	Extended sizes available.
Standard Colour:	RAL 5015 Blue
Forklift Facility:	Available at an additional cost of £150.00 and extended delivery time.

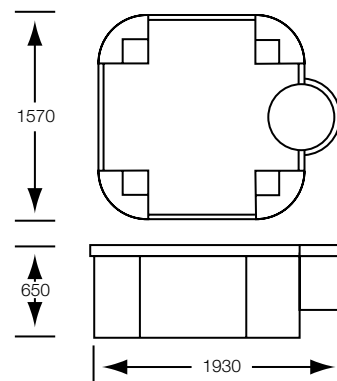

To order call: 01206 798 798

All prices exclude VAT. FREE delivery prices are to anywhere in England, Scotland and Wales. Orders placed before midday will usually be despatched the following day. Usual delivery 2-3 days.

Sui Generis International Ltd.

The Chandler's Centre
Hythe Quay
Colchester
CO2 8JF
Tel: 01206 798 798
Fax: 01206 866 666
Email: info@sui generis.co.uk
www.sui generis.co.uk

Fibreglass Linings
Industrial Coatings
Surface Preparation
Spill Containment

Fibreglass Mouldings
Anti-slip Stair Covers
Anti-slip Floor Sheets
Fibreglass Grating

Spill Containment

IBC Bund, Spill Pallet or Sump Pallet - SG104

£670 FREE delivery. Quantity discounts available.

Spill containment for 2 x 1000 litre IBC's. Without dispensing facility.

Designed for the long term safe bunding of IBC's and suitable for all oils and 95% of chemicals, IBC Bund Spill Pallets help you comply with current oil and chemical storage regulations.

Why buy Sui Generis IBC Bund Spill Pallets?

Tough reinforced composite construction.
Broad range chemical compatibility.
Retains long term structural integrity.
Lighter than steel or polyethylene for easy manual handling.
Simply shaped for easy cleaning.
Order and bund your next IBC sooner with a UDL of 3000 kgs.
Large catchment area around IBC to contain leaks.
10 Year Guarantee.

Benefits:

Protects the workplace, environment and personnel.
Designed for most sizes of IBC.
Maintenance free.

Compliance:

Compliant with the 110% bund regulations.
No taps or drainage points to compromise the bund area.

10 Year Guarantee

As the UK manufacturer we offer quality products at competitive prices. Should you receive a more competitive like for like quotation, we guarantee to beat it.

To order call: 01206 798 798

All prices exclude VAT. FREE delivery prices are to anywhere in England, Scotland and Wales. Orders placed before midday will usually be despatched the following day. Usual delivery 2-3 days.



SG104

Principal Material:	GRP (Glass Reinforced Plastic)
External Dimensions:	2810 x 1670 x 370 mm
Regulation Capacity:	1100 litres
Actual Capacity:	1100+ litres
Maximum UDL:	3000 kgs
Weight:	Circa 60 kgs
Maximum size of IBC:	1270 length x 1100 width mm
Minimum size of IBC:	1110 length x 950 width mm
	Extended sizes available.
Standard Colour:	RAL 5015 Blue

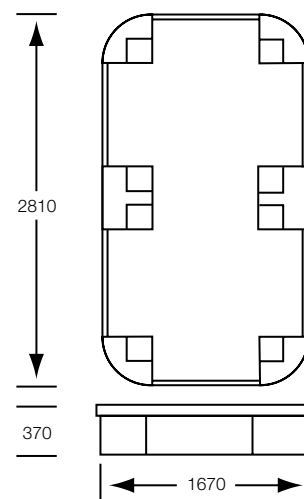

Sui Generis International Ltd.

The Chandler's Centre
Hythe Quay
Colchester
CO2 8JF
Tel: 01206 798 798
Fax: 01206 866 666
Email: info@sui generis.co.uk
www.sui generis.co.uk

Fibreglass Linings
Industrial Coatings
Surface Preparation
Spill Containment

Fibreglass Mouldings
Anti-slip Stair Covers
Anti-slip Floor Sheets
Fibreglass Grating

Spill Containment

IBC Bund, Spill Pallet or Sump Pallet - SG105

£695 FREE delivery. Quantity discounts available.

Spill containment for 2 x 1000 litre IBC's. With dispensing facility.

Designed for the long term safe bunding of IBC's and suitable for all oils and 95% of chemicals, IBC Bund Spill Pallets help you comply with current oil and chemical storage regulations.

Why buy Sui Generis IBC Bund Spill Pallets?

Tough reinforced composite construction.
Broad range chemical compatibility.
Retains long term structural integrity.
Lighter than steel or polyethylene for easy manual handling.
Simply shaped for easy cleaning.
Order and bund your next IBC sooner with a UDL of 3000 kgs.
Low sides to ease the manual handling of dispensed liquids.
Large catchment area around IBC to contain leaks.
10 Year Guarantee.

Benefits:

Protects the workplace, environment and personnel.
Designed for most sizes of IBC.
Maintenance free.

Compliance:

Compliant with the 110% bund regulations.
No taps or drainage points to compromise the bund area.

10 Year Guarantee

As the UK manufacturer we offer quality products at competitive prices. Should you receive a more competitive like for like quotation, we guarantee to beat it.

To order call: 01206 798 798

All prices exclude VAT. FREE delivery prices are to anywhere in England, Scotland and Wales. Orders placed before midday will usually be despatched the following day. Usual delivery 2-3 days.



SG105

Principal Material:	GRP (Glass Reinforced Plastic)
External Dimensions:	2810 x 1930 x 470 mm
Regulation Capacity:	1100 litres
Actual Capacity:	1100+ litres
Maximum UDL:	3000 kgs
Weight:	Circa 65 kgs
Maximum size of IBC:	1270 length x 1100 width mm
Minimum size of IBC:	1110 length x 950 width mm
	Extended sizes available.
Standard Colour:	RAL 5015 Blue

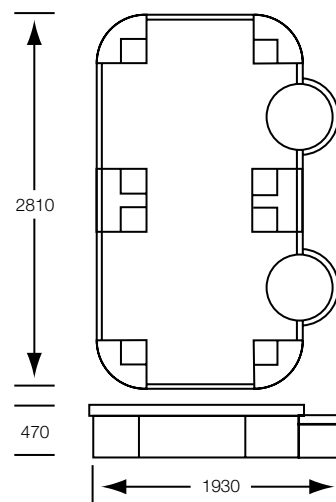

Sui Generis International Ltd.

The Chandler's Centre
Hythe Quay
Colchester
CO2 8JF
Tel: 01206 798 798
Fax: 01206 866 666
Email: info@sui generis.co.uk
www.sui generis.co.uk

Fibreglass Linings
Industrial Coatings
Surface Preparation
Spill Containment

Fibreglass Mouldings
Anti-slip Stair Covers
Anti-slip Floor Sheets
Fibreglass Grating

Spill Containment

IBC Bund, Spill Pallet or Sump Pallet - SG109

£850 FREE delivery. Quantity discounts available.

Spill containment for 4 x 1000 litre IBC's. Without dispensing facility.

Designed for the long term safe bunding of IBC's and suitable for all oils and 95% of chemicals, IBC Bund Spill Pallets help you comply with current oil and chemical storage regulations.

Why buy Sui Generis IBC Bund Spill Pallets?

Tough reinforced composite construction.
Broad range chemical compatibility.
Retains long term structural integrity.
Lighter than steel or polyethylene for easy manual handling.
Simply shaped for easy cleaning.
Order and bund your next IBC sooner with a UDL of 6000 kgs.
Large catchment area around IBC to contain leaks.
10 Year Guarantee.

Benefits:

Protects the workplace, environment and personnel.
Designed for most sizes of IBC.
Maintenance free.

Compliance:

Compliant with the 110% bund regulations.
No taps or drainage points to compromise the bund area.

10 Year Guarantee

As the UK manufacturer we offer quality products at competitive prices. Should you receive a more competitive like for like quotation, we guarantee to beat it.

To order call: 01206 798 798

All prices exclude VAT. FREE delivery prices are to anywhere in England, Scotland and Wales. Orders placed before midday will usually be despatched the following day. Usual delivery 2-3 days.



SG109

Principal Material:	GRP (Glass Reinforced Plastic)
External Dimensions:	2810 x 1670 x 370 mm
Regulation Capacity:	1000 litres
Actual Capacity:	1100+ litres
Maximum UDL:	6000 kgs
Weight:	Circa 75 kgs
Maximum size of IBC:	1270 length x 1100 width mm
Minimum size of IBC:	1110 length x 950 width mm
	Extended sizes available.
Standard Colour:	RAL 5015 Blue

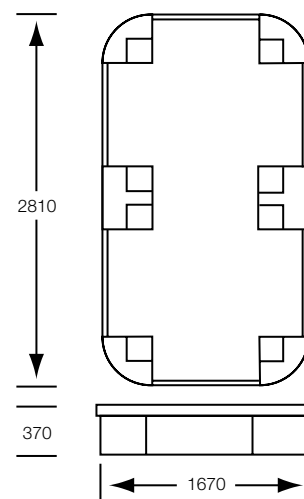

Sui Generis International Ltd.

The Chandler's Centre
Hythe Quay
Colchester
CO2 8JF
Tel: 01206 798 798
Fax: 01206 866 666
Email: info@sui generis.co.uk
www.sui generis.co.uk

Fibreglass Linings
Industrial Coatings
Surface Preparation
Spill Containment

Fibreglass Mouldings
Anti-slip Stair Covers
Anti-slip Floor Sheets
Fibreglass Grating

Spill Containment

IBC Bund, Spill Pallet or Sump Pallet - SG110

£880 FREE delivery. Quantity discounts available.

Spill containment for 4 x 1000 litre IBC's. With dispensing facility.

Designed for the long term safe bunding of IBC's and suitable for all oils and 95% of chemicals, IBC Bund Spill Pallets help you comply with current oil and chemical storage regulations.

Why buy Sui Generis IBC Bund Spill Pallets?

Tough reinforced composite construction.
Broad range chemical compatibility.
Retains long term structural integrity.
Lighter than steel or polyethylene for easy manual handling.
Simply shaped for easy cleaning.
Order and bund your next IBC sooner with a UDL of 6000 kgs.
Low sides to ease the manual handling of dispensed liquids.
Large catchment area around IBC to contain leaks.
10 Year Guarantee.

Benefits:

Protects the workplace, environment and personnel.
Designed for most sizes of IBC.
Maintenance free.

Compliance:

Compliant with the 110% bund regulations.
No taps or drainage points to compromise the bund area.

10 Year Guarantee

As the UK manufacturer we offer quality products at competitive prices. Should you receive a more competitive like for like quotation, we guarantee to beat it.

To order call: 01206 798 798

All prices exclude VAT. FREE delivery prices are to anywhere in England, Scotland and Wales. Orders placed before midday will usually be despatched the following day. Usual delivery 2-3 days.



SG110

Principal Material:	GRP (Glass Reinforced Plastic)
External Dimensions:	2810 x 1930 x 470 mm
Regulation Capacity:	1000 litres
Actual Capacity:	1100+ litres
Maximum UDL:	6000 kgs
Weight:	Circa 75 kgs
Maximum size of IBC:	1270 length x 1100 width mm
Minimum size of IBC:	1110 length x 950 width mm
	Extended sizes available.
Standard Colour:	RAL 5015 Blue

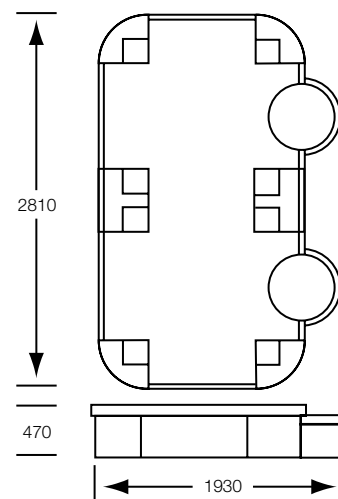

Sui Generis International Ltd.

The Chandler's Centre
Hythe Quay
Colchester
CO2 8JF
Tel: 01206 798 798
Fax: 01206 866 666
Email: info@sui generis.co.uk
www.sui generis.co.uk

Fibreglass Linings
Industrial Coatings
Surface Preparation
Spill Containment

Fibreglass Mouldings
Anti-slip Stair Covers
Anti-slip Floor Sheets
Fibreglass Grating

Spill Containment

6 x IBC Bund, Spill Pallet or Sump Pallet - SG106

£1,725 Quantity discounts available.

Spill containment for up to 6 x 1000 litre IBC's.

Designed for the long term safe bunding of IBC's and suitable for all oils and 95% of chemicals. IBC Bund Spill Pallets catch leaks, drips and spills to help you comply with current oil and chemical storage regulations, and keep your storage areas clean.

Why buy Sui Generis IBC Bund Spill Pallets?

Cost effective IBC storage: store up to six IBC tanks on one unit, avoiding the cost of buying multiple units.
Tough reinforced composite construction - withstands the rigours of a working environment.
Broad range chemical compatibility - no need to purchase a new unit if your storage use changes.
Retains long term structural integrity - will not warp over time.
Lighter than steel or polyethylene - easily repositioned without risk of manual handling injury.
Simply shaped - easily emptied or cleaned.
UDL of 7200 kgs.
Large catchment area - our IBC bunds have twice the catchment area of some other products on the market.
No taps or drainage points to compromise the bund area.
10 Year Guarantee.

Benefits:

Protects the workplace, environment and personnel.
Designed for most sizes of IBC.
Maintenance free.

Compliance:

Compliant with the 110% bund regulations.
No taps or drainage points to compromise the bund area.

10 Year Guarantee



10 YEAR
GUARANTEE

SG106

Principal Material:	GRP (Glass Reinforced Plastic)
External Dimensions:	2500mm x 1750mm x 500 high
Regulation Capacity:	1500 litres
Actual Capacity:	1755 litres
Maximum UDL:	7200 kgs
Weight:	circa 250 kgs
Standard Colour:	RAL 5015 Blue

ALL SIZES IN MM

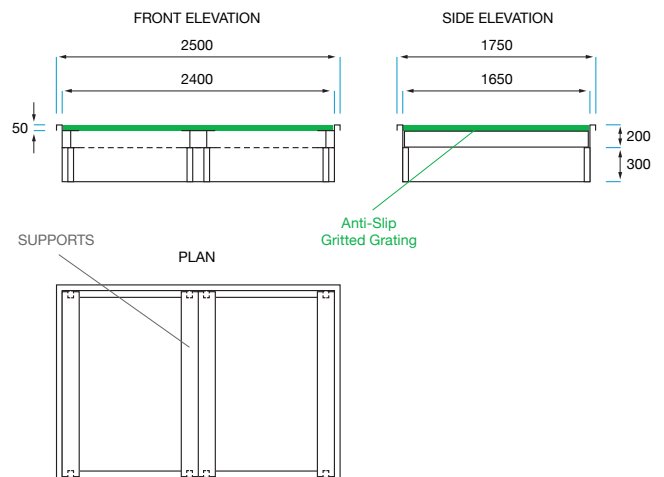

To order call: 01206 798 798

All prices exclude VAT. Delivery extra.
Usual delivery within 2 weeks of receipt of order.

Sui Generis International Ltd.

The Chandler's Centre
Hythe Quay
Colchester
CO2 8JF
Tel: 01206 798 798
Fax: 01206 866 666
Email: info@sui generis.co.uk
www.sui generis.co.uk

Fibreglass Linings
Industrial Coatings
Surface Preparation
Spill Containment

Fibreglass Mouldings
Anti-slip Stair Covers
Anti-slip Floor Sheets
Fibreglass Grating

Spill Containment

6 x IBC Bund, Spill Pallet or Sump Pallet - SG107

£2,495 Quantity discounts available.

Spill containment for up to 6 x 1000 litre IBC's.

Designed for the long term safe bunding of IBC's and suitable for all oils and 95% of chemicals. IBC Bund Spill Pallets catch leaks, drips and spills to help you comply with current oil and chemical storage regulations, and keep your storage areas clean.

Why buy Sui Generis IBC Bund Spill Pallets?

Cost effective IBC storage: store up to nine IBC tanks on one unit, avoiding the cost of buying multiple units.
Tough reinforced composite construction - withstands the rigours of a working environment.
Broad range chemical compatibility - no need to purchase a new unit if your storage use changes.
Retains long term structural integrity - will not warp over time.
Lighter than steel or polyethylene - easily repositioned without risk of manual handling injury.
Simply shaped - easily emptied or cleaned.
UDL of 9900 kgs.
Large catchment area - our IBC bunds have twice the catchment area of some other products on the market.
No taps or drainage points to compromise the bund area.
10 Year Guarantee.

Benefits:

Protects the workplace, environment and personnel.
Designed for most sizes of IBC.
Maintenance free.

Compliance:

Compliant with the 110% bund regulations.
No taps or drainage points to compromise the bund area.

10 Year Guarantee



SG107

Principal Material:	GRP (Glass Reinforced Plastic)
External Dimensions:	3500mm x 1750mm x 500 high
Regulation Capacity:	1500 litres
Actual Capacity:	2475 litres
Maximum UDL:	9900 kgs
Weight:	circa 390 kgs
Standard Colour:	RAL 5015 Blue

ALL SIZES IN MM

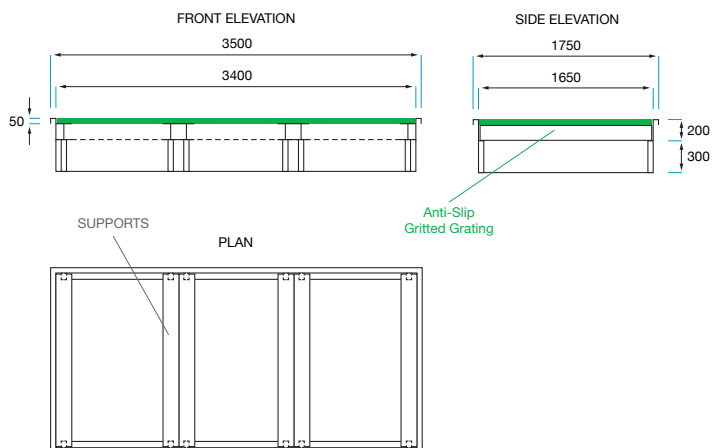

To order call: 01206 798 798

All prices exclude VAT. Delivery extra.
Usual delivery within 2 weeks of receipt of order.

Sui Generis International Ltd.

The Chandler's Centre
Hythe Quay
Colchester
CO2 8JF
Tel: 01206 798 798
Fax: 01206 866 666
Email: info@sui generis.co.uk
www.sui generis.co.uk

Fibreglass Linings
Industrial Coatings
Surface Preparation
Spill Containment

Fibreglass Mouldings
Anti-slip Stair Covers
Anti-slip Floor Sheets
Fibreglass Grating

Spill Containment

8 x IBC Bund, Spill Pallet or Sump Pallet - SG108

£3,340 Quantity discounts available.

Spill containment for up to 8 x 1000 litre IBC's.

Designed for the long term safe bunding of IBC's and suitable for all oils and 95% of chemicals.
IBC Bund Spill Pallets catch leaks, drips and spills to help you comply with current oil and chemical storage regulations, and keep your storage areas clean.

Why buy Sui Generis IBC Bund Spill Pallets?

Cost effective IBC storage: store up to twelve IBC tanks on one unit, avoiding the cost of buying multiple units.
Tough reinforced composite construction - withstands the rigours of a working environment.
Broad range chemical compatibility - no need to purchase a new unit if your storage use changes.
Retains long term structural integrity - will not warp over time.
Lighter than steel or polyethylene - easily repositioned without risk of manual handling injury.
Simply shaped - easily emptied or cleaned.
UDL of 13,200 kgs.
Large catchment area - our IBC bunds have twice the catchment area of some other products on the market.
No taps or drainage points to compromise the bund area.
10 Year Guarantee.

Benefits:

Protects the workplace, environment and personnel.
Designed for most sizes of IBC.
Maintenance free.

Compliance:

Compliant with the 110% bund regulations.
No taps or drainage points to compromise the bund area.

10 Year Guarantee



SG108

Principal Material:	GRP (Glass Reinforced Plastic)
External Dimensions:	4500mm x 1750mm x 500 high
Regulation Capacity:	2000 litres
Actual Capacity:	3160 litres
Maximum UDL:	13,200 kgs
Weight:	circa 520 kgs
Standard Colour:	RAL 5015 Blue

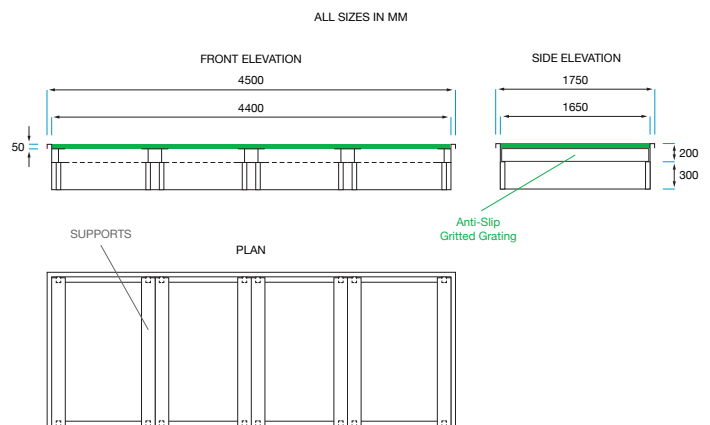

To order call: 01206 798 798

All prices exclude VAT. Delivery extra.
Usual delivery within 2 weeks of receipt of order.

Sui Generis International Ltd.

The Chandler's Centre
Hythe Quay
Colchester
CO2 8JF
Tel: 01206 798 798
Fax: 01206 866 666
Email: info@sui generis.co.uk
www.sui generis.co.uk

Fibreglass Linings
Industrial Coatings
Surface Preparation
Spill Containment

Fibreglass Mouldings
Anti-slip Stair Covers
Anti-slip Floor Sheets
Fibreglass Grating

Spill Containment

9 x IBC Bund, Spill Pallet or Sump Pallet - SG107

£2,495 Quantity discounts available.

Spill containment for up to 9 x 1000 litre IBC's.

Designed for the long term safe bunding of IBC's and suitable for all oils and 95% of chemicals. IBC Bund Spill Pallets catch leaks, drips and spills to help you comply with current oil and chemical storage regulations, and keep your storage areas clean.

Why buy Sui Generis IBC Bund Spill Pallets?

Cost effective IBC storage: store up to nine IBC tanks on one unit, avoiding the cost of buying multiple units. Tough reinforced composite construction - withstands the rigours of a working environment. Broad range chemical compatibility - no need to purchase a new unit if your storage use changes. Retains long term structural integrity - will not warp over time. Lighter than steel or polyethylene - easily repositioned without risk of manual handling injury. Simply shaped - easily emptied or cleaned. UDL of 9900 kgs. Large catchment area - our IBC bunds have twice the catchment area of some other products on the market. No taps or drainage points to compromise the bund area. 10 Year Guarantee.

Benefits:

Protects the workplace, environment and personnel. Designed for most sizes of IBC. Maintenance free.

Compliance:

Compliant with the 110% bund regulations. No taps or drainage points to compromise the bund area.

10 YEAR
GUARANTEE



SG107

Principal Material:	GRP (Glass Reinforced Plastic)
External Dimensions:	3500mm x 1750mm x 500 high
Regulation Capacity:	2250 litres
Actual Capacity:	2475 litres
Maximum UDL:	9900 kgs
Weight:	circa 390 kgs
Standard Colour:	RAL 5015 Blue

ALL SIZES IN MM

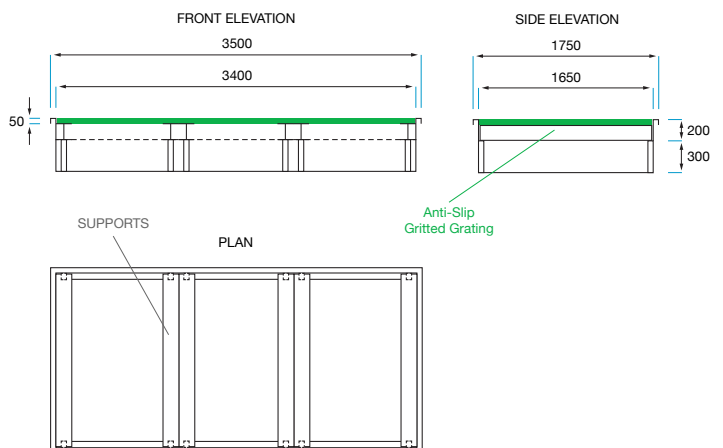

10 Year Guarantee

To order call: 01206 798 798

All prices exclude VAT. Delivery extra.
Usual delivery within 2 weeks of receipt of order.

Sui Generis International Ltd.

The Chandler's Centre
Hythe Quay
Colchester
CO2 8JF
Tel: 01206 798 798
Fax: 01206 866 666
Email: info@sui generis.co.uk
www.sui generis.co.uk

Fibreglass Linings
Industrial Coatings
Surface Preparation
Spill Containment

Fibreglass Mouldings
Anti-slip Stair Covers
Anti-slip Floor Sheets
Fibreglass Grating

Spill Containment

12 x IBC Bund, Spill Pallet or Sump Pallet - SG108

£3,340 Quantity discounts available.

Spill containment for up to 12 x 1000 litre IBC's.

Designed for the long term safe bunding of IBC's and suitable for all oils and 95% of chemicals.

IBC Bund Spill Pallets catch leaks, drips and spills to help you comply with current oil and chemical storage regulations, and keep your storage areas clean.

Why buy Sui Generis IBC Bund Spill Pallets?

Cost effective IBC storage: store up to twelve IBC tanks on one unit, avoiding the cost of buying multiple units.

Tough reinforced composite construction - withstands the rigours of a working environment.

Broad range chemical compatibility - no need to purchase a new unit if your storage use changes.

Retains long term structural integrity - will not warp over time.

Lighter than steel or polyethylene - easily repositioned without risk of manual handling injury.

Simply shaped - easily emptied or cleaned.

UDL of 13,200 kgs.

Large catchment area - our IBC bunds have twice the catchment area of some other products on the market.

No taps or drainage points to compromise the bund area.

10 Year Guarantee.

Benefits:

Protects the workplace, environment and personnel.

Designed for most sizes of IBC.

Maintenance free.

Compliance:

Compliant with the 110% bund regulations.

No taps or drainage points to compromise the bund area.

10 Year Guarantee



SG108

Principal Material:	GRP (Glass Reinforced Plastic)
External Dimensions:	4500mm x 1750mm x 500 high
Regulation Capacity:	3000 litres
Actual Capacity:	3160 litres
Maximum UDL:	13,200 kgs
Weight:	circa 520 kgs
Standard Colour:	RAL 5015 Blue

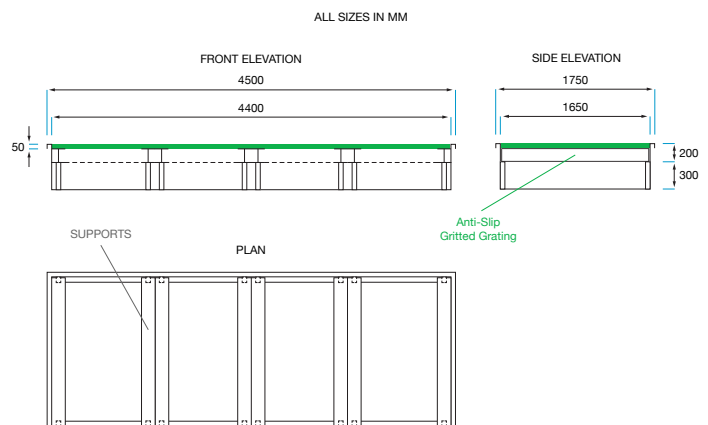

To order call: 01206 798 798

All prices exclude VAT. Delivery extra.

Usual delivery within 2 weeks of receipt of order.

Sui Generis International Ltd.

The Chandler's Centre
Hythe Quay
Colchester
CO2 8JF

Tel: 01206 798 798
Fax: 01206 866 666
Email: info@sui generis.co.uk
www.sui generis.co.uk

Fibreglass Linings
Industrial Coatings
Surface Preparation
Spill Containment

Fibreglass Mouldings
Anti-slip Stair Covers
Anti-slip Floor Sheets
Fibreglass Grating

Spill Containment

IBC Bund Spill Pallet - User Health & Safety Instructions for SG101, 102, 104, 105, 109, 110

The IBC Bund will give many years of service by just following the simple guidelines below.

Siting the IBC Bund

The IBC Bund should be sited and fully supported on a flat uniform level surface of a sufficiently strong and stable nature, and should be clean of stones and any other objects. A bed of soft sand cement mix can be used if the site is uneven.

Loading the IBC Spill Containment Bundstand

Forklift users should be instructed to lower the IBC unit as carefully and as level as possible on the Bund.

The IBC unit must sit on the recessed pads, avoid lowering onto elevated surfaces. The forks should be withdrawn free of snagging the IBC Bund rim or any part of the IBC unit.

Forklift users should be made aware that the single IBC Bund is not square and the IBC unit should be loaded correctly. The IBC unit nozzle should face toward the narrowest side. IBC Bunds with a drain off bucket facility cannot be loaded from the bucket side.

The IBC unit should not be loaded onto the Bund while the IBC Bund is on a pallet.

Spillages

In the event of a spill and in harmony with good housekeeping, cleanups should occur immediately and any residual liquid neutralised. However, data sheets should be consulted and the health and safety officer or responsible person should supervise all cleanups. Waste should be disposed of in accord with the manufacturers direction.

The units are designed/supplied for secondary containment of spillage, and not for primary containment unless otherwise agreed in writing.

Use

The IBC Bund is designed to cope with a variety of environments and is suitable for 95% of all liquids to be stored. Please refer to our chemical resistance chart showing the range of liquids that can be safely banded:

<http://www.suigeneris.co.uk/pdfs/Spill-Containment-Chemical-Resistance-Charts.pdf>

When drawing from the IBC unit directly into a container, sensible practices should be followed such as not overfilling the container, not leaving the container whilst being filled, the wearing of appropriate gloves, etc. The filled container should not be removed from the IBC Bund without first making sure the IBC valve is turned off and not leaking fluid.

Storage

Thoroughly clean and store on a flat surface.

Moving the IBC Spill Containment Bund

The IBC Bund can be lifted quite comfortably by two healthy personnel. It is recommended that when moving the location of the IBC Bund it is manhandled onto a pallet and moved by forklift. If relocating please refer to 'Siting the IBC Bund' (top left).

When manhandling the IBC Bund sensible lifting practices should be employed:

- Do not:-
- Drag the IBC Bund
 - Forklift without a pallet

Under no circumstances should any IBC Bund be moved while accommodating an IBC unit.



SG105
Spill containment for
2 x 1000 litre IBC.
With dispensing
facility.

Sui Generis International Ltd.

The Chandler's Centre
Hythe Quay
Colchester
CO2 8JF
Tel: 01206 798 798
Fax: 01206 866 666
Email: info@suigeneris.co.uk
www.suigeneris.co.uk

Fibreglass Linings
Industrial Coatings
Surface Preparation
Spill Containment

Fibreglass Mouldings
Anti-slip Stair Covers
Anti-slip Floor Sheets
Fibreglass Grating

Spill Containment

IBC Bund Spill Pallet - User Health & Safety Instructions for SG106, SG107, SG108

The IBC Bund will give many years of service by just following the simple guidelines below.

Siting the IBC Bund

The IBC Bund should be sited and fully supported on a flat uniform level surface of a sufficiently strong and stable nature, and should be clean of stones and any other objects.

Loading the IBC Spill Containment Bundstand

Forklift users should be instructed to lower the IBC unit as carefully and as level as possible on the Bund, centrally over the grating supports.

The forks should be withdrawn free of snagging the IBC Bund rim or any part of the IBC unit.

The IBC unit nozzle should face toward the front.

Spillages

In the event of a spill and in harmony with good housekeeping, cleanups should occur immediately and any residual liquid neutralised. However, data sheets should be consulted and the Health and Safety Officer or responsible person should supervise all cleanups. Waste should be disposed of in accord with the manufacturers direction.

The units are designed/supplied for secondary containment of spillage, and not for primary containment unless otherwise agreed in writing.

Use

The IBC Bund is designed to cope with a variety of environments and is suitable for 95% of all liquids to be stored. Please refer to our chemical resistance chart showing the range of liquids that can be safely banded:

<http://www.suigeneris.co.uk/pdfs/Spill-Containment-Chemical-Resistance-Charts.pdf>



SG108 - Bund up to 12 x 1000 litre IBCs.



SG107 - Bund up to 9 x 1000 litre IBCs.

Sui Generis International Ltd.

The Chandler's Centre
Hythe Quay
Colchester
CO2 8JF
Tel: 01206 798 798
Fax: 01206 866 666
Email: info@suigeneris.co.uk
www.suigeneris.co.uk

Fibreglass Linings
Industrial Coatings
Surface Preparation
Spill Containment

Fibreglass Mouldings
Anti-slip Stair Covers
Anti-slip Floor Sheets
Fibreglass Grating

Spill Containment

1 Drum Spill Tray - SG201

£180 FREE delivery. Quantity discounts available.

25% Spill Capacity for 1 x 205 litre Drum.

Suitable for all oils and 95% of chemicals, the 1 Drum Spill Tray helps you comply with current oil and chemical storage regulations.

With unique anti-slip gritted grating

The specially designed fibreglass construction is simply shaped with a removable support surface, so your bund can be easily emptied or cleaned. Also, the heavy-duty anti-slip gritted grating allows you to position your drums without sliding.

Why buy Sui Generis Drum Bunds?

Tough reinforced composite construction.
Broad range chemical compatibility.
Retains long term structural integrity.
Lighter than steel or polyethylene for easy manual handling.
Simply shaped with removable support surface for easy cleaning.
Heavy-duty anti-slip support surface.
10 Year Guarantee.

Benefits:

Protects the workplace, environment and personnel.
Maintenance free.

10 Year Guarantee

As the UK manufacturer we offer quality products at competitive prices. Should you receive a more competitive like for like quotation, we guarantee to beat it.

To order call: 01206 798 798

All prices exclude VAT. FREE delivery prices are to anywhere in England, Scotland and Wales. Orders placed before midday will usually be despatched the following day. Usual delivery 2-3 days.



SG201

Principal Material:	GRP (Glass Reinforced Plastic)
Support Material:	Anti-slip Fibreglass Grating
External Dimensions:	850 x 850 x 160 mm
Capacity:	55 litres
Maximum Loading:	500 kgs
Weight:	Circa 20 kgs
Standard Colour:	RAL 5015 Blue + RAL 6029 Green

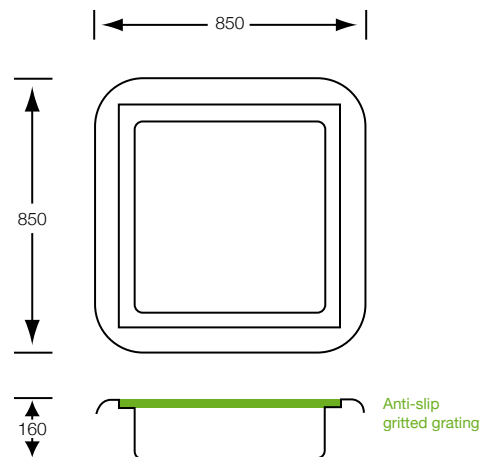

Sui Generis International Ltd.

The Chandler's Centre
Hythe Quay
Colchester
CO2 8JF
Tel: 01206 798 798
Fax: 01206 866 666
Email: info@sui generis.co.uk
www.sui generis.co.uk

Fibreglass Linings
Industrial Coatings
Surface Preparation
Spill Containment

Fibreglass Mouldings
Anti-slip Stair Covers
Anti-slip Floor Sheets
Fibreglass Grating

Spill Containment

1 Drum Spill Pallet with forklift facility - SG201-FL

£250 FREE delivery. Quantity discounts available.

25% Spill Capacity for 1 x 205 litre Drum.

Suitable for all oils and 95% of chemicals, the 1 Drum Spill Pallet helps you comply with current oil and chemical storage regulations.

With unique forklift friendly & anti-slip features

Specially designed to aid the transportation of your drums, the fibreglass construction is much stronger than polyethylene, both bund and drums can be moved together safely. When using a forklift drum grabber attachment, drums can be positioned without sliding, thanks to the specially gritted grating surface.

Why buy Sui Generis Drum Pallets?

- Tough reinforced composite construction.
- Broad range chemical compatibility.
- Retains long term structural integrity.
- Can be moved while fully loaded.
- Simply shaped with removable support surface for easy cleaning.
- Heavy-duty anti-slip support surface.
- 10 Year Guarantee.

Benefits:

- Protects the workplace, environment and personnel.
- Maintenance free.

10 Year Guarantee

As the UK manufacturer we offer quality products at competitive prices. Should you receive a more competitive like for like quotation, we guarantee to beat it.

To order call: 01206 798 798

All prices exclude VAT. FREE delivery prices are to anywhere in England, Scotland and Wales. Orders placed before midday will usually be despatched the following day. Usual delivery 2-3 days.



SG201-FL

Principal Material:	GRP (Glass Reinforced Plastic)
Support Material:	Anti-slip Fibreglass Grating
External Dimensions:	850 x 850 x 290 mm
Capacity:	55 litres
Maximum Loading:	500 kgs
Weight:	Circa 25 kgs
Standard Colour:	RAL 5015 Blue + RAL 6029 Green

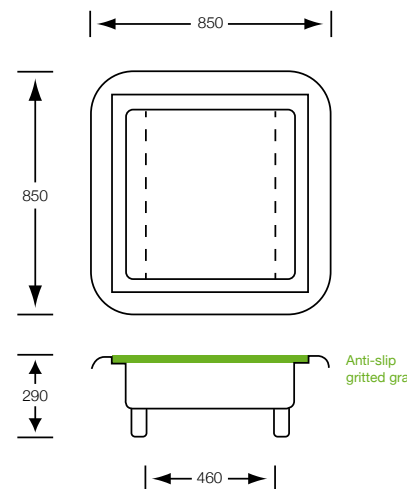

Sui Generis International Ltd.

The Chandler's Centre
Hythe Quay
Colchester
CO2 8JF
Tel: 01206 798 798
Fax: 01206 866 666
Email: info@sui generis.co.uk
www.sui generis.co.uk

Fibreglass Linings
Industrial Coatings
Surface Preparation
Spill Containment

Fibreglass Mouldings
Anti-slip Stair Covers
Anti-slip Floor Sheets
Fibreglass Grating

Spill Containment

2 Drum Bund - SG202

£235 FREE delivery. Quantity discounts available.

Spill containment for 2 x 205 litre Drums.

Designed for the long term safe bunding of drums and suitable for all oils and 95% of chemicals, the 2 Drum Bund helps you comply with current oil and chemical storage regulations.

With unique anti-slip gritted grating

The specially designed fibreglass construction is simply shaped with a removable support surface, so your bund can be easily emptied or cleaned. Also, the heavy-duty anti-slip gritted grating allows you to position your drums without sliding.

Why buy Sui Generis Drum Bunds?

- Tough reinforced composite construction.
- Broad range chemical compatibility.
- Retains long term structural integrity.
- Lighter than steel or polyethylene for easy manual handling.
- Simply shaped with removable support surface for easy cleaning.
- Heavy-duty anti-slip support surface.
- 10 Year Guarantee.

Benefits:

- Protects the workplace, environment and personnel.
- Maintenance free.

10 Year Guarantee

As the UK manufacturer we offer quality products at competitive prices. Should you receive a more competitive like for like quotation, we guarantee to beat it.

To order call: 01206 798 798

All prices exclude VAT. FREE delivery prices are to anywhere in England, Scotland and Wales. Orders placed before midday will usually be despatched the following day. Usual delivery 2-3 days.



SG202

Principal Material:	GRP (Glass Reinforced Plastic)
Support Material:	Anti-slip Fibreglass Grating
External Dimensions:	1380 x 850 x 400 mm
Regulation Capacity:	220 litres
Actual Capacity:	270 litres
Maximum Loading:	1000 kgs
Weight:	Circa 30 kgs
Standard Colour:	RAL 5015 Blue + RAL 6029 Green

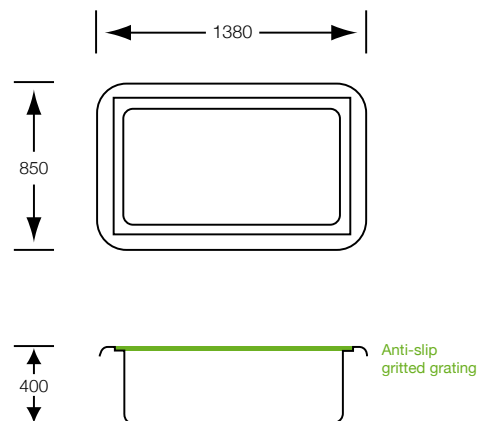

Sui Generis International Ltd.

The Chandler's Centre
Hythe Quay
Colchester
CO2 8JF
Tel: 01206 798 798
Fax: 01206 866 666
Email: info@sui generis.co.uk
www.sui generis.co.uk

Fibreglass Linings
Industrial Coatings
Surface Preparation
Spill Containment
Fibreglass Mouldings
Anti-slip Stair Covers
Anti-slip Floor Sheets
Fibreglass Grating

Spill Containment

2 Drum Pallet with forklift facility - SG202-FL

£330 FREE delivery. Quantity discounts available.

Spill containment for 2 x 205 litre Drums.

Designed for the long term safe bunding of drums and suitable for all oils and 95% of chemicals, the 2 Drum Pallet helps you comply with current oil and chemical storage regulations.

With unique forklift friendly & anti-slip features

Specially designed to aid the transportation of your drums, the fibreglass construction is much stronger than polyethylene, both bund and drums can be moved together safely. When using a forklift drum grabber attachment, drums can be positioned without sliding, thanks to the specially gritted grating surface.

Why buy Sui Generis Drum Pallets?

- Tough reinforced composite construction.
- Broad range chemical compatibility.
- Retains long term structural integrity.
- Can be moved while fully loaded.
- Simply shaped with removable support surface for easy cleaning.
- Heavy-duty anti-slip support surface.
- 10 Year Guarantee.

Benefits:

- Protects the workplace, environment and personnel.
- Maintenance free.

10 Year Guarantee

As the UK manufacturer we offer quality products at competitive prices. Should you receive a more competitive like for like quotation, we guarantee to beat it.

To order call: 01206 798 798

All prices exclude VAT. FREE delivery prices are to anywhere in England, Scotland and Wales. Orders placed before midday will usually be despatched the following day. Usual delivery 2-3 days.



SG202-FL

Principal Material:	GRP (Glass Reinforced Plastic)
Support Material:	Anti-slip Fibreglass Grating
External Dimensions:	1380 x 850 x 530 mm
Regulation Capacity:	220 litres
Actual Capacity:	270 litres
Maximum Loading:	1000 kgs
Weight:	Circa 45 kgs
Standard Colour:	RAL 5015 Blue + RAL 6029 Green

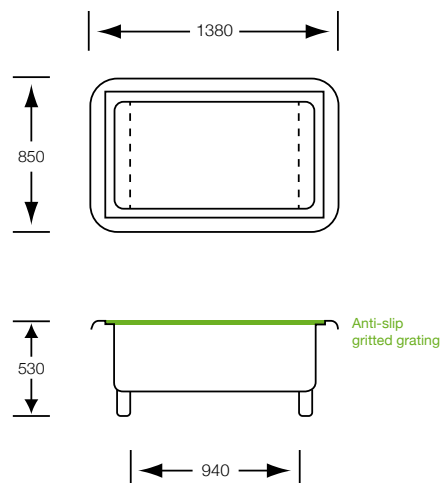

Sui Generis International Ltd.

The Chandler's Centre
Hythe Quay
Colchester
CO2 8JF
Tel: 01206 798 798
Fax: 01206 866 666
Email: info@sui generis.co.uk
www.sui generis.co.uk

Fibreglass Linings
Industrial Coatings
Surface Preparation
Spill Containment
Fibreglass Mouldings
Anti-slip Stair Covers
Anti-slip Floor Sheets
Fibreglass Grating

Spill Containment

4 - 8 Drum Bund - SG203

£370 FREE delivery. Quantity discounts available.

Spill containment for 4 x 205 litre Drums.

Designed for the long term safe bunding of drums and suitable for all oils and 95% of chemicals, the 4-8 Drum Bund helps you comply with current oil and chemical storage regulations.

With unique anti-slip gritted grating

The specially designed fibreglass construction is simply shaped with a removable support surface, so your bund can be easily emptied or cleaned. Also, the heavy-duty anti-slip gritted grating allows you to position your drums without sliding.

Why buy Sui Generis Drum Bunds?

- Tough reinforced composite construction.
- Broad range chemical compatibility.
- Retains long term structural integrity.
- Lighter than steel or polyethylene for easy manual handling.
- Simply shaped with removable support surface for easy cleaning.
- Heavy-duty anti-slip support surface.
- 10 Year Guarantee.

Benefits:

- Protects the workplace, environment and personnel.
- Maintenance free.

10 Year Guarantee

As the UK manufacturer we offer quality products at competitive prices. Should you receive a more competitive like for like quotation, we guarantee to beat it.

To order call: 01206 798 798

All prices exclude VAT. FREE delivery prices are to anywhere in England, Scotland and Wales. Orders placed before midday will usually be despatched the following day. Usual delivery 2-3 days.



SG203

Principal Material:	GRP (Glass Reinforced Plastic)
Support Material:	Anti-slip Fibreglass Grating
External Dimensions:	1380 x 1380 x 220 mm
Regulation Capacity:	220 litres
Actual Capacity:	290 litres
Maximum UDL:	2500 kgs
Weight:	Circa 45 kgs
Standard Colour:	RAL 5015 Blue + RAL 6029 Green

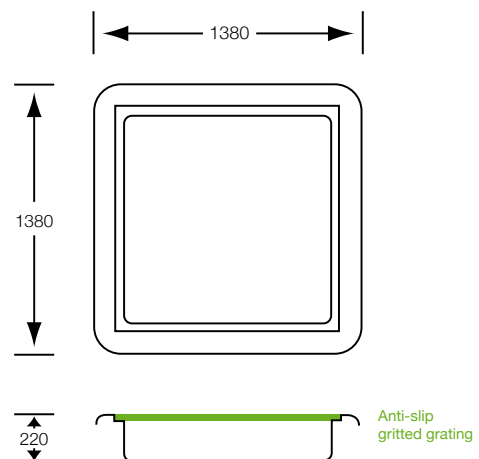

Sui Generis International Ltd.

The Chandler's Centre
Hythe Quay
Colchester
CO2 8JF

Tel: 01206 798 798
Fax: 01206 866 666
Email: info@sui generis.co.uk
www.sui generis.co.uk

Fibreglass Linings
Industrial Coatings
Surface Preparation
Spill Containment

Fibreglass Mouldings
Anti-slip Stair Covers
Anti-slip Floor Sheets
Fibreglass Grating

Spill Containment

4 - 8 Drum Pallet with forklift facility - SG203-FL

£505 FREE delivery. Quantity discounts available.

Spill containment for 4 x 205 litre Drums.

Designed for the long term safe bunding of drums and suitable for all oils and 95% of chemicals, the 4-8 Drum Pallet helps you comply with current oil and chemical storage regulations.

With unique forklift friendly & anti-slip features

Specially designed to aid the transportation of your drums, the fibreglass construction is much stronger than polyethylene, both bund and drums can be moved together safely. When using a forklift drum grabber attachment, drums can be positioned without sliding, thanks to the specially gritted grating surface.

Why buy Sui Generis Drum Pallets?

- Tough reinforced composite construction.
- Broad range chemical compatibility.
- Retains long term structural integrity.
- Can be moved while fully loaded.
- Simply shaped with removable support surface for easy cleaning.
- Heavy-duty anti-slip support surface.
- 10 Year Guarantee.

Benefits:

- Protects the workplace, environment and personnel.
- Maintenance free.

10 Year Guarantee

As the UK manufacturer we offer quality products at competitive prices. Should you receive a more competitive like for like quotation, we guarantee to beat it.

To order call: 01206 798 798

All prices exclude VAT. FREE delivery prices are to anywhere in England, Scotland and Wales. Orders placed before midday will usually be despatched the following day. Usual delivery 2-3 days.



SG203-FL

Principal Material:	GRP (Glass Reinforced Plastic)
Support Material:	Anti-slip Fibreglass Grating
External Dimensions:	1380 x 1380 x 350 mm
Regulation Capacity:	220 litres
Actual Capacity:	290 litres
Maximum UDL:	2500 kgs
Weight:	Circa 65 kgs
Standard Colour:	RAL 5015 Blue + RAL 6029 Green

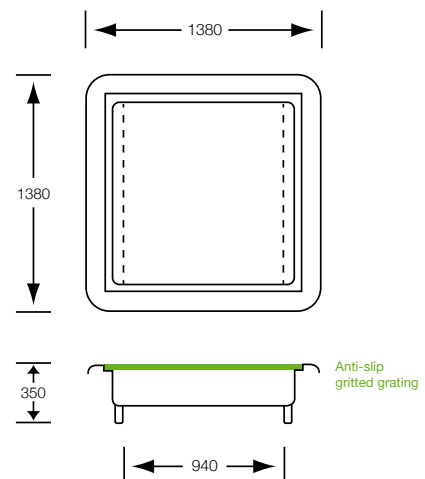

Sui Generis International Ltd.

The Chandler's Centre
Hythe Quay
Colchester
CO2 8JF
Tel: 01206 798 798
Fax: 01206 866 666
Email: info@sui generis.co.uk
www.sui generis.co.uk

Fibreglass Linings
Industrial Coatings
Surface Preparation
Spill Containment
Fibreglass Mouldings
Anti-slip Stair Covers
Anti-slip Floor Sheets
Fibreglass Grating

Spill Containment

7 Drum Bund - SG205

£880 FREE delivery. Quantity discounts available.

Spill containment for 7 x 205 litre Drums.

Designed for the long term safe bunding of drums and suitable for all oils and 95% of chemicals, the 7 Drum Bund helps you comply with current oil and chemical storage regulations.

Ideal for hand barrel trolleys

Specially designed for safe storage of your drums. When using a hand barrel trolley, drums can easily be moved and positioned without sliding, thanks to the specially gritted grating surface.

Why buy Sui Generis Drum Bunds?

- Tough reinforced composite construction.
- Broad range chemical compatibility.
- Retains long term structural integrity.
- Lighter than steel or polyethylene for easy manual handling.
- Simply shaped with removable support surface for easy cleaning.
- Heavy-duty anti-slip support surface.
- 10 Year Guarantee.

Benefits:

- Protects the workplace, environment and personnel.
- Maintenance free.
- Low profile for easy manual loading.

10 Year Guarantee



SG205

Principal Material:	GRP (Glass Reinforced Plastic)
Support Material:	Anti-slip Fibreglass Grating
External Dimensions:	4300 x 700 x 100 mm
Regulation Capacity:	220 litres
Actual Capacity:	250 litres
Maximum UDL:	2000 kgs
Weight:	Circa 90 kgs
Standard Colour:	RAL 5015 Blue + RAL 7035 Grey

As the UK manufacturer we offer quality products at competitive prices. Should you receive a more competitive like for like quotation, we guarantee to beat it.

To order call: 01206 798 798

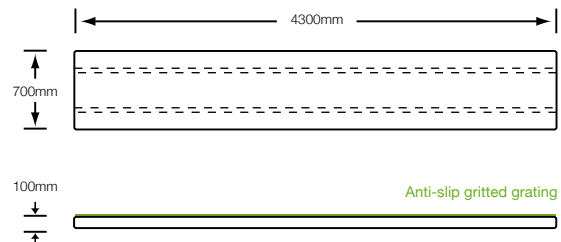

All prices exclude VAT. FREE delivery prices are to anywhere in England, Scotland and Wales.
Usual delivery within 2 weeks from order.

Sui Generis International Ltd.

The Chandler's Centre
Hythe Quay
Colchester
CO2 8JF
Tel: 01206 798 798
Fax: 01206 866 666
Email: info@sui generis.co.uk
www.sui generis.co.uk

Fibreglass Linings
Industrial Coatings
Surface Preparation
Spill Containment

Fibreglass Mouldings
Anti-slip Stair Covers
Anti-slip Floor Sheets
Fibreglass Grating

Spill Containment

Bunded Drum Trolley - SG204

£390 FREE delivery. Quantity discounts available.

For dispensing and spill containment for 1 x 205 litre Drums.

Designed for easier dispensing and safe bunding of drums. Suitable for all oils and 95% of chemicals, the Bunded Drum Trolley helps you comply with current oil and chemical storage regulations.

Why buy a Bunded Drum Trolley?

Tough reinforced composite / steel construction.
Broad range chemical compatibility.
Retains long term structural integrity.
Simply shaped for easy cleaning.
Easy to load and tip.
Anti-tip safety stops.
Heavy-duty wheels.
Accepts 25 litre kegs for dispensing.
10 Year Guarantee.

Benefits:

Protects the workplace, environment and personnel.

10 Year Guarantee

As the UK manufacturer we offer quality products at competitive prices. Should you receive a more competitive like for like quotation, we guarantee to beat it.

To order call: 01206 798 798

All prices exclude VAT. FREE delivery prices are to anywhere in England, Scotland and Wales. Orders placed before midday will usually be despatched the following day. Usual delivery 2-3 days.



SG204

Principal Material:	GRP (Glass Reinforced Plastic)
External Dimensions:	1620 x 670 x 590mm
Regulation Capacity:	220 litres
Actual Capacity:	250 litres
Weight:	Circa 30 kgs
Standard Colour:	RAL 5015 Blue

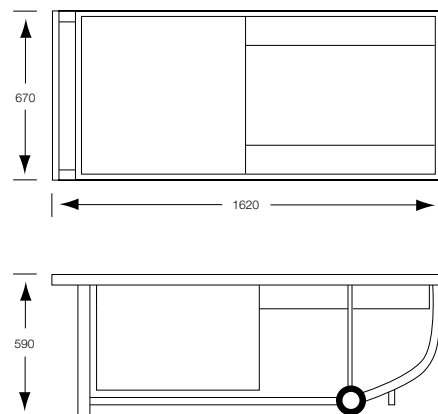

Sui Generis International Ltd.

The Chandler's Centre
Hythe Quay
Colchester
CO2 8JF

Tel: 01206 798 798
Fax: 01206 866 666
Email: info@sui generis.co.uk
www.sui generis.co.uk

Fibreglass Linings
Industrial Coatings
Surface Preparation
Spill Containment

Fibreglass Mouldings
Anti-slip Stair Covers
Anti-slip Floor Sheets
Fibreglass Grating

Spill Containment

Tank Bund - SG301

£975 Excluding delivery. Quantity discounts available.

Spill containment for up to 2000 litres. 2 supports.

Designed for the long term bunding of vessels, tanks, containers etc. up to 2000 litres. Steel supports can be factory-fitted to suit your specific requirements. Suitable for all oils and 95% of chemicals, Tank Bunds help you comply with current oil and chemical storage regulations.

Why buy a Sui Generis Tank Bund?

Tough reinforced composite construction.
Broad range chemical compatibility.
Retains long term structural integrity.
Simply shaped for easy cleaning.

Benefits:

Protects the workplace, environment and personnel.
5000 kg maximum uniformly distributed load.
Easy to relocate.

Compliance:

Compliant with the 110% bund regulations.
No taps or drainage points to compromise the bund area.



SG301

Principal Material:	GRP (Glass Reinforced Plastic)
External Dimensions:	2200 x 2200 x 600 mm
Nominal Capacity:	2000 litres
Actual Capacity:	2250 litres
Maximum UDL:	5000 kgs
Weight:	140 kgs
Standard Colour:	RAL 5015 Blue

As the UK manufacturer we offer quality products at competitive prices. Should you receive a more competitive like for like quotation, we guarantee to beat it.

To order call: 01206 798 798

All prices exclude VAT. Delivery extra.
Usual delivery within 2 weeks of receipt of order.

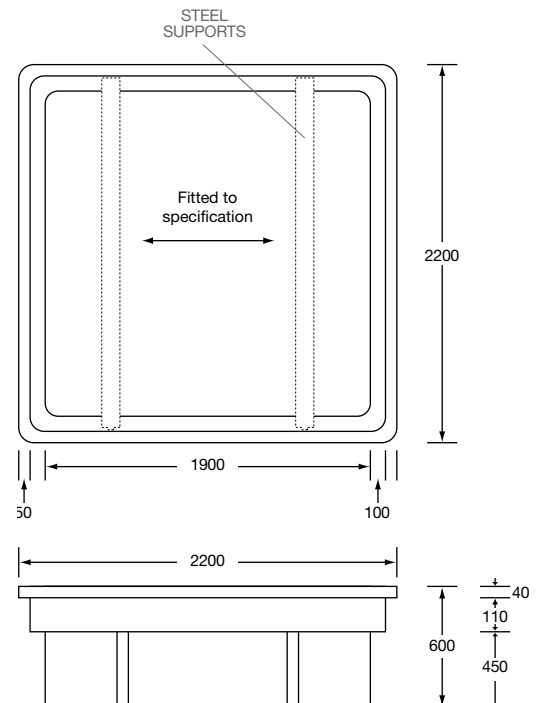

Sui Generis International Ltd.

The Chandler's Centre
Hythe Quay
Colchester
CO2 8JF
Tel: 01206 798 798
Fax: 01206 866 666
Email: info@sui generis.co.uk
www.sui generis.co.uk

Fiberglass Linings
Industrial Coatings
Surface Preparation
Spill Containment

Fiberglass Mouldings
Anti-slip Stair Covers
Anti-slip Floor Sheets
Fiberglass Grating

Spill Containment

Tank Bund - SG302

£1,125 Excluding delivery. Quantity discounts available.

Spill containment for up to 2000 litres. 3 supports.

Designed for the long term bunding of vessels, tanks, containers etc. up to 2000 litres. Steel supports can be factory-fitted to suit your specific requirements. Suitable for all oils and 95% of chemicals, Tank Bunds help you comply with current oil and chemical storage regulations.

Why buy a Sui Generis Tank Bund?

Tough reinforced composite construction.
Broad range chemical compatibility.
Retains long term structural integrity.
Simply shaped for easy cleaning.

Benefits:

Protects the workplace, environment and personnel.
5000 kg maximum uniformly distributed load.
Easy to relocate.

Compliance:

Compliant with the 110% bund regulations.
No taps or drainage points to compromise the bund area.



SG302

Principal Material:	GRP (Glass Reinforced Plastic)
External Dimensions:	2200 x 2200 x 600mm
Nominal Capacity:	2000 litres
Actual Capacity:	2250 litres
Maximum UDL:	5000 kgs
Weight:	170 kgs
Standard Colour:	RAL 5015 Blue

As the UK manufacturer we offer quality products at competitive prices. Should you receive a more competitive like for like quotation, we guarantee to beat it.

To order call: 01206 798 798

All prices exclude VAT. Delivery extra.
Usual delivery within 2 weeks of receipt of order.

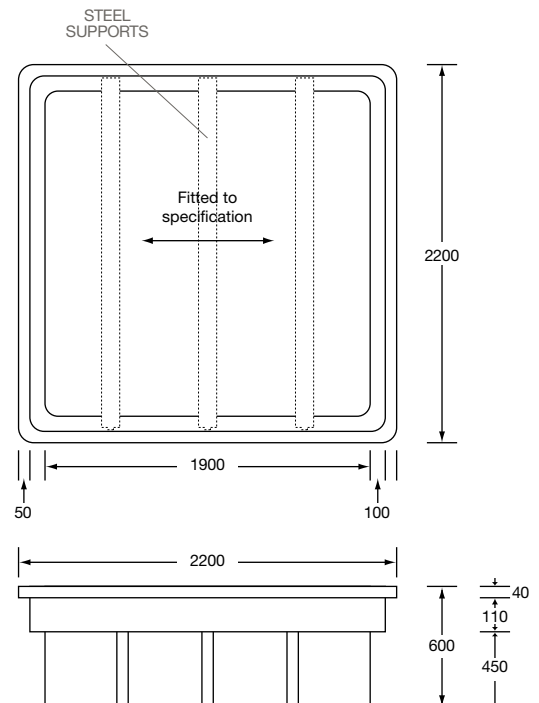

Sui Generis International Ltd.

The Chandler's Centre
Hythe Quay
Colchester
CO2 8JF
Tel: 01206 798 798
Fax: 01206 866 666
Email: info@sui generis.co.uk
www.sui generis.co.uk

Fibreglass Linings
Industrial Coatings
Surface Preparation
Spill Containment

Fibreglass Mouldings
Anti-slip Stair Covers
Anti-slip Floor Sheets
Fibreglass Grating

Spill Containment

Tank Bund - SG303

£1,745 Excluding delivery. Quantity discounts available.

Spill containment for up to 2000 litres. With 4 supports & removable grated platform.

Designed for the long term bunding of vessels, tanks, containers etc. up to 2000 litres. Suitable for all oils and 95% of chemicals, Tank Bunds help you comply with current oil and chemical storage regulations.

With unique anti-slip gritted grating

The specially designed fibreglass construction is simply shaped with a removable support surface, so your tank bund can be easily emptied or cleaned. The heavy-duty anti-slip gritted grating allows you to position tanks without sliding.

Why buy a Sui Generis Tank Bund?

Tough reinforced composite construction.
Broad range chemical compatibility.
Retains long term structural integrity.
Simply shaped for easy cleaning.

Benefits:

Protects the workplace, environment and personnel.
5000 kg maximum uniformly distributed load.
Easy to relocate.

Compliance:

Compliant with the 110% bund regulations.
No taps or drainage points to compromise the bund area.



SG303

Principal Material:	GRP (Glass Reinforced Plastic)
Support Material:	Anti-slip Fibreglass Grating
External Dimensions:	2200 x 2200 x 625mm
Nominal Capacity:	2000 litres
Actual Capacity:	2250 litres
Maximum UDL:	5000 kgs
Weight:	280 kgs
Standard Colour:	RAL 5015 Blue

As the UK manufacturer we offer quality products at competitive prices. Should you receive a more competitive like for like quotation, we guarantee to beat it.

To order call: 01206 798 798

All prices exclude VAT. Delivery extra.
Usual delivery within 2 weeks of receipt of order.

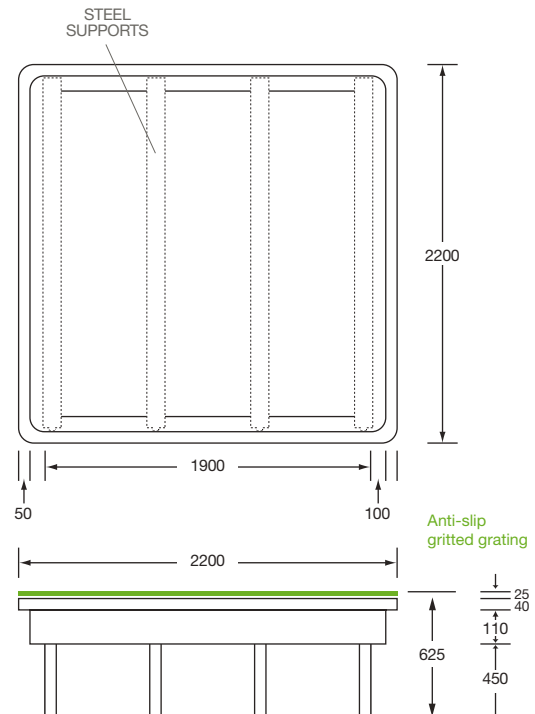

Sui Generis International Ltd.

The Chandler's Centre
Hythe Quay
Colchester
CO2 8JF
Tel: 01206 798 798
Fax: 01206 866 666
Email: info@sui generis.co.uk
www.sui generis.co.uk

Fibreglass Linings
Industrial Coatings
Surface Preparation
Spill Containment

Fibreglass Mouldings
Anti-slip Stair Covers
Anti-slip Floor Sheets
Fibreglass Grating

Spill Containment

Standard Bunds - SG401-409

The Sui Generis standard bund range has been developed to fulfil spill containment needs of customers who require bunding for permanently sited liquid storage tanks, vessels, and containers etc, specifically those up to 6000 litres in capacity. Quick and easy to install, available in a range of sizes and capacities, the one piece moulded GRP units are a much more viable long term solution to traditional block or brick on concrete built bunds. Standard Bunds help you comply with current oil and chemical storage regulations.

Why buy a Sui Generis Standard Bund?

Tough reinforced composite construction.
Broad range chemical compatibility.
Retains long term structural integrity.
Lightweight.
Easy to install.
Simply shaped for easy cleaning.
10 Year Guarantee.

Benefits:

Protects the workplace, environment and personnel.
Maintenance free.

Compliance:

Compliant with the 110% bund regulations.
No taps or drainage points to compromise the bund area.

10 Year Guarantee

As the UK manufacturer we offer quality products at competitive prices. Should you receive a more competitive like for like quotation, we guarantee to beat it.

To order call: 01206 798 798

All prices exclude VAT. Delivery extra.
Usual delivery within 2 weeks of receipt of order.



SG401-409

Principal Material: GRP (Glass Reinforced Plastic)
Standard Colour: RAL 5015 Blue

SG401 1200 litres, weight: circa 60 kgs 3200 x 2200 x 200mm	£720
SG402 1800 litres, weight: circa 70 kgs 3200 x 2200 x 300mm	£780
SG403 2400 litres, weight: circa 75 kgs 3200 x 2200 x 400mm	£845
SG404 1900 litres, weight: circa 90 kgs 4200 x 2600 x 200mm	£1,070
SG405 2850 litres, weight: circa 100 kgs 4200 x 2600 x 300mm	£1,150
SG406 3800 litres, weight: circa 110 kgs 4200 x 2600 x 400mm	£1,235
SG407 3360 litres, weight: circa 140 kgs 6200 x 3000 x 200mm	£1,865
SG408 5040 litres, weight: circa 155 kgs 6200 x 3000 x 300mm	£1,975
SG409 6720 litres, weight: circa 170 kgs 6200 x 3000 x 400mm	£2,085

Sui Generis International Ltd.

The Chandler's Centre
Hythe Quay
Colchester
CO2 8JF
Tel: 01206 798 798
Fax: 01206 866 666
Email: info@sui generis.co.uk
www.sui generis.co.uk

Fibreglass Linings
Industrial Coatings
Surface Preparation
Spill Containment

Fibreglass Mouldings
Anti-slip Stair Covers
Anti-slip Floor Sheets
Fibreglass Grating

Spill Containment

Custom Built Bunds and Spill Trays

Tailor made to your exact requirements, our custom built bunds are more economical than you might think. Your bund will be manufactured in a resin finish to suit your specific liquid storage requirements providing you with a cost effective long term solution to your bunding needs.

Why buy a Sui Generis Custom Built Bund or Spill Tray?

Made to suit your exact needs.
Tough reinforced composite construction.
Broad range chemical compatibility.
Retains long term structural integrity.
Lightweight.
Easy to install.

Benefits:

Protects the workplace, environment and personnel.
Maintenance free.

Compliance:

Compliant with the 110% bund regulations.
No taps or drainage points to compromise the bund area.

As the UK manufacturer we offer quality products at competitive prices. Should you receive a more competitive like for like quotation, we guarantee to beat it.

To get a quotation for your exact requirements call: 01206 798 798

All prices exclude VAT. Delivery extra.
Usual delivery within 2 weeks of receipt of order.

Previous Projects & Indicative Prices



500 x 500 x 500mm.
£100

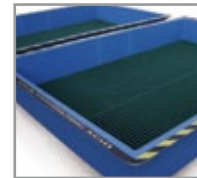

Hydrochloric acid bunds.
3000 x 2000 x 400mm.
£1,110 inc. grated floor.

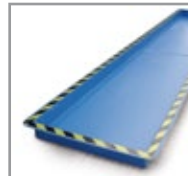

5000 x 900 x 150mm.
£560



Ramp storage area
£2,795

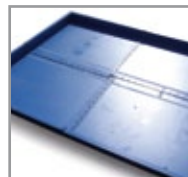

Generator Drip Tray -
made in four sections
for ease of installation.
3000 x 2500 x 150mm.
£1,575

Additional features you can incorporate into the design:

Anti-slip flooring into the manufacture process.
Anti-slip fibreglass grating as an internal floor to allow oils or products to flow underneath creating a safer walking surface.
GRP walkways, platforms or access steps.
Hazard identification markings.

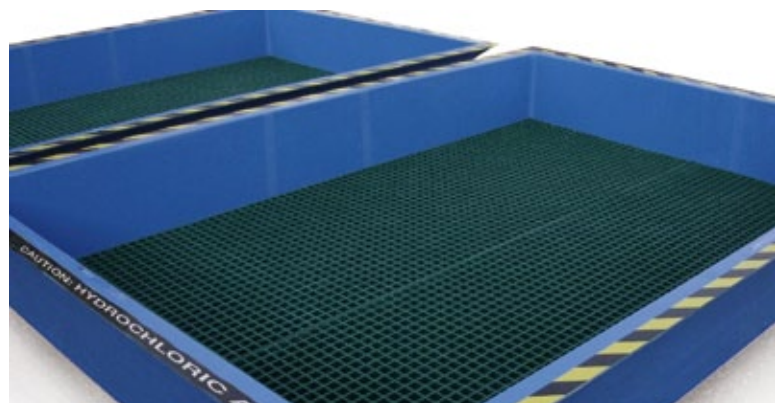

Sui Generis International Ltd.

The Chandler's Centre
Hythe Quay
Colchester
CO2 8JF
Tel: 01206 798 798
Fax: 01206 866 666
Email: info@sui generis.co.uk
www.sui generis.co.uk

Fibreglass Linings
Industrial Coatings
Surface Preparation
Spill Containment

Fibreglass Mouldings
Anti-slip Stair Covers
Anti-slip Floor Sheets
Fibreglass Grating

Spill Containment

Custom Built Bunds and Spill Trays

IBC Bund with removable side.

Tailor made to your exact requirements, our custom built bunds are more economical than you might think. Your bund will be manufactured in a resin finish to suit your specific liquid storage requirements providing you with a cost effective long term solution to your bunding needs.

Why buy a Sui Generis Custom Built Bund or Spill Tray?

Made to suit your exact needs.
Tough reinforced composite construction.
Broad range chemical compatibility.
Retains long term structural integrity.
Lightweight.
Easy to install.

Benefits:

Protects the workplace, environment and personnel.
Maintenance free.

Compliance:

Compliant with the 110% bund regulations.
No taps or drainage points to compromise the bund area.

As the UK manufacturer we offer quality products at competitive prices. Should you receive a more competitive like for like quotation, we guarantee to beat it.

To get a quotation for your exact requirements call: 01206 798 798

All prices exclude VAT. Delivery extra.
Usual delivery within 2 weeks of receipt of order.



Sui Generis International Ltd.

The Chandler's Centre
Hythe Quay
Colchester
CO2 8JF
Tel: 01206 798 798
Fax: 01206 866 666
Email: info@sui generis.co.uk
www.sui generis.co.uk

Fibreglass Linings
Industrial Coatings
Surface Preparation
Spill Containment

Fibreglass Mouldings
Anti-slip Stair Covers
Anti-slip Floor Sheets
Fibreglass Grating