

Standard Equipment/Optional Equipment

Standard Equipment

General

- Four wheel configuration
- Pneumatic tyres
- Tractor without cab
- Left or right hand drive steering position
- Adjustable steering column
- Comprehensive integrated display
- Single pedal accelerator and direction lever
- Full suspension PVC driver's seat
- Non-suspension PVC passenger seat
- Hydrostatic power steering
- Two exterior mirrors
- Remote inching control
- Automatic single position, rear towing coupling
- Trailer lighting socket
- Dual circuit hydraulic disc brakes on all four wheels
- Standard colour scheme - vermilion and charcoal grey
- Full road lighting
- Heated rear screen (with full cabin)

Electronics

- 80 V circuit/highly efficient energy saving system
- 2 x 10 kW maintenance free AC drive motors
- Advanced Linde AC digital controller
- Precise control of speed and acceleration
- Programmable performance parameters

Batteries and chargers

- P 250 SWB - 80V, 400 to 620 Ah to IEC
- P250 LWB - 80V, 600 to 930 Ah to IEC
- Easy vertical lift out battery change
- A range of chargers is available to suit application

Safety

- Keyswitch
- Emergency circuit isolator/Fails to safe circuitry
- Traction isolated by seatswitch and/or parking brake
- Electrical overload protection
- Comprehensive warning lights
- Electric horn

Optional Equipment

- Cab with flexible roll up sides
- Cab without sides
- Cab with sliding or hinged doors
- Optional cab with front and rear screen wipers/washers
- Rear lights mounted high at rear of cab
- Flashing or rotating beacon on cab
- Reverse warning beeper
- Contoured solid (superelastic) tyres
- Towing couplings:
 - Automatic single position, front and/or rear
 - Automatic single position, remote, rear
 - Multi-position, front and/or rear

- 240 mm rear coupling extension
- Electric or diesel heater and demister
- Fabric covered seats
- Heated seats
- Full suspension passenger seat
- Alternative colour schemes



Electric Tow Tractor Capacity 25000 kg P 250

Series 127-03

Safety

The heavy duty chassis and cab module provide assured protection for the operator while three independent braking systems deliver responsive stopping power for all situations including automatic speed control descending gradients. A low centre of gravity ensures outstanding stability.

Performance

With a nominal towing capacity of 25.0 tonne and unladen traction speed of 25 km/h the P 250 offers flexible high performance which is optimised by the Linde digital AC control system providing precise, energy saving control of acceleration and speed for high productivity. The curved front screen and profiled chassis ensures excellent manoeuvrability.

Comfort

A low step facilitates access to spacious operator's cabin where the automotive layout of the pedals, direction lever, steering wheel and controls, together with a fully adjustable suspension seat provides a comfortable and fatigue-free working environment. Cab suspension dampers and a spring damped suspension system front and rear ensures superb levels of driving comfort.

Features

Chassis

- Long and short wheelbase versions
- Robot welded heavy gauge steel plate
- Maximum torsional resistance and rigidity
- High impact protection for operator and components
- Low profile chassis for all-round visibility

Ergonomics

- Ergonomic automotive pedal and control layout
- Spacious leg and headroom
- Storage space for documents, pens and beverage holder
- Excellent all-round visibility
- Clear view to rear tow coupling



Operator's compartment

- Low step access to spacious cabin
- Sliding or hinged cabin doors
- Fully adjustable comfort-class operator's seat
- Cabin isolated from chassis by hydraulic dampers
- Multi-function instrument display

Steering

- Hydrostatic power steering
- Effortless manoeuvrability
- Adjustable steering column
- Large lock-to-lock angle

Braking

- Three independent braking systems
- Electric push-button parking brake
- Hydraulic disc brakes (front) external disc brakes (rear)
- Regenerative electric braking as accelerator pedal is released
- Superb regenerative braking control on gradients



Tow coupling

- Automatic rear towing coupling as standard
- Optional remote automatic and multi-position couplings
- Front and rear towing coupling options
- Stand-off inching control as standard

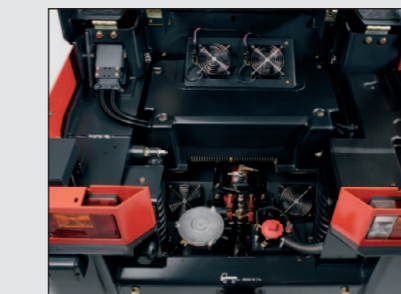

Drive unit

- Two 10 kW maintenance-free AC drive motors
- Integrated in drive axle with no differential required
- Superb traction with anti-slip control
- Reduced power to inner wheel during cornering
- High-torque flexibility and performance

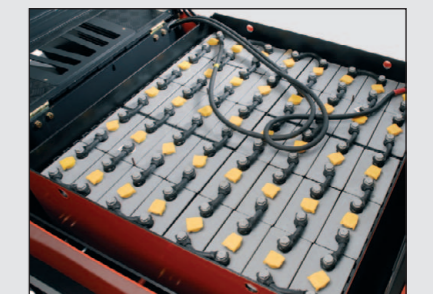

Serviceability

- Hinged rear platform cover
- Easy access for maintenance and battery
- CAN bus diagnostic facility for reduced service intervals
- Multi-function instrument display assists scheduled maintenance planning
- Maintenance-free AC drive technology

Linde Material Handling



Technical Data according to VDI 2198

Category	Item No.	Parameter	P250 (SWB) ¹⁾	P250 (LWB) ¹⁾		
Characteristics	1.1	Manufacturer	LINDE	LINDE		
	1.2	Model designation	P250 (SWB)¹⁾	P250 (LWB)¹⁾		
	1.3	Power unit	Battery	Battery		
	1.4	Operation	Seat	Seat		
	1.5	Load capacity	Q (t)	25.0 ¹⁾	25.0 ¹⁾	
	1.7	Rated tractive force	F (N)	5000 ¹⁾	5000 ¹⁾	
	1.9	Wheelbase	y (mm)	1465	1900	
	Weights	2.1	Service weight	(kg)	3800	4800
		2.2	Axle load with load, front/rear	(kg)	2000 / 2100	2600 / 2500
2.3		Axle load without load, front/rear	(kg)	1900 / 1900	2500 / 2300	
Wheels/Tyres	3.1	Tyres rubber, SE, pneumatic, polyurethane	Pneumatic	Pneumatic		
	3.2	Tyre size, front	6.00 R9	6.00 R9		
	3.3	Tyre size, rear	7.00 R12	7.00 R12		
	3.5	Wheels, number front/rear (x = driven)	2 / 2x	2 / 2x		
	3.6	Track width, front	b10 (mm)	1080	1080	
	3.7	Track width, rear	b11 (mm)	1020	1020	
	Dimensions	4.7	Height of overhead guard (cabin)	h6 (mm)	1820	1820
4.8		Height of seat/stand-on platform	h7 (mm)	745	745	
4.12		Towing coupling height	h10 (mm)	240, 295, 350, 405	240, 295, 350, 405	
4.13		Platform height, unladen	h11 (mm)	1000	1000	
4.16		Loading platform, length	l3 (mm)	1520	1955	
4.17		Rear overhang	l5 (mm)	615	615	
4.18		Loading platform, width	b9 (mm)	1170 (1120) ²⁾	1170 (1120) ²⁾	
4.19		Overall length	l1 (mm)	3045	3480	
4.21		Overall width	b1/b2 (mm)	1300	1300	
4.32		Ground clearance, centre of wheelbase	m2 (mm)	150	150	
4.35		Turning radius	Wa (mm)	2830	3280	
4.36		Minimum pivoting point distance	b13 (mm)	935	1095	
Performance		5.1	Travel speed, with/without load	(km/h)	11 / 25 ³⁾	11 / 25 ³⁾
	5.5	Tractive force, with/without load	(N)	5000	5000	
	5.6	Maximum tractive force, with/without load	(N)	16000	16000	
	5.7	Climbing ability, with/without load	(%)	see performance graph	see performance graph	
	5.8	Maximum climbing ability, with/without load	(%)	see performance graph	see performance graph	
Service brake	5.10	Service brake	Electric/hydraulic	Electric/hydraulic		
	6.1	Drive motor, 60 minute rating	(kW)	2x 10	2x 10	
Drive	6.3	Battery according to DIN 43531/35/36 A,B,C,no		43 536 / A	43 536 / A	
	6.4	Battery voltage/rated capacity (5h)	(V/Ah)	80 / 620	80 / 930	
	6.5	Battery weight (± 5%)	(kg)	1558	2178	
	6.6	Power consumption according to VDI cycle	(kWh/h)	upon request	upon request	
	Others	8.1	Type of drive control	AC - microprocessor	AC - microprocessor	
8.4		Noise level at operator's ear	(dB(A))	upon request	upon request	
8.5		Towing coupling, design/type, DIN 15 170		upon request	upon request	

1) Based on level, dry surface with rolling resistance of 200 N/t. Refer to towing.
2) at rear

3) 72 V circuit available Traction speed is reduced by 10%.

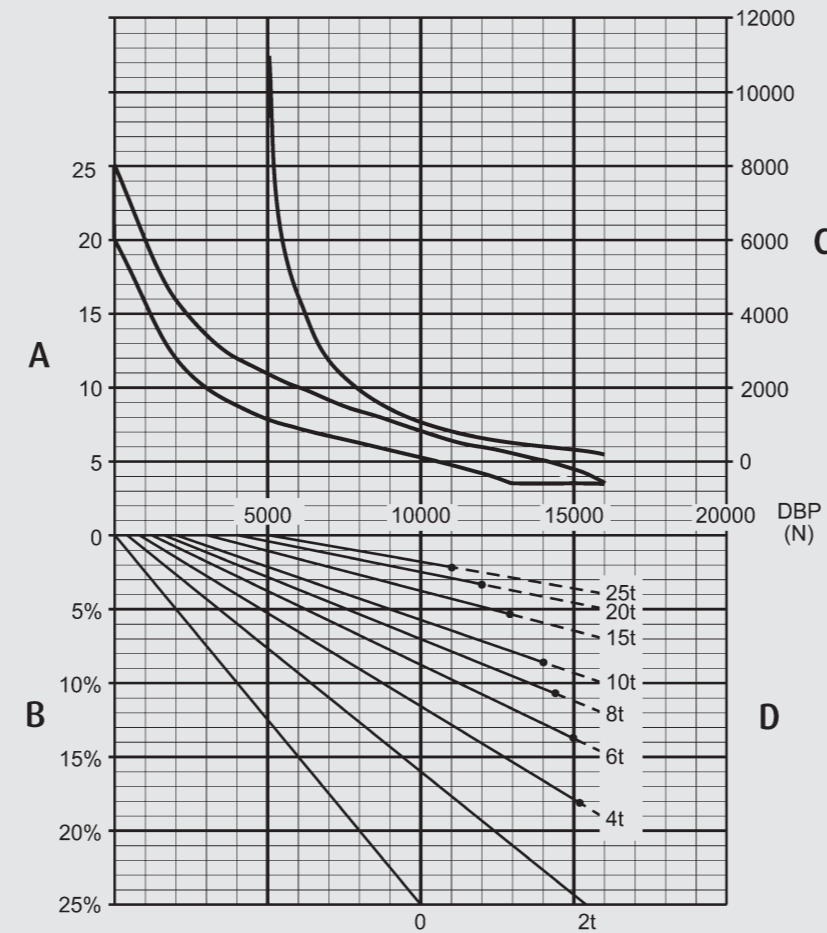
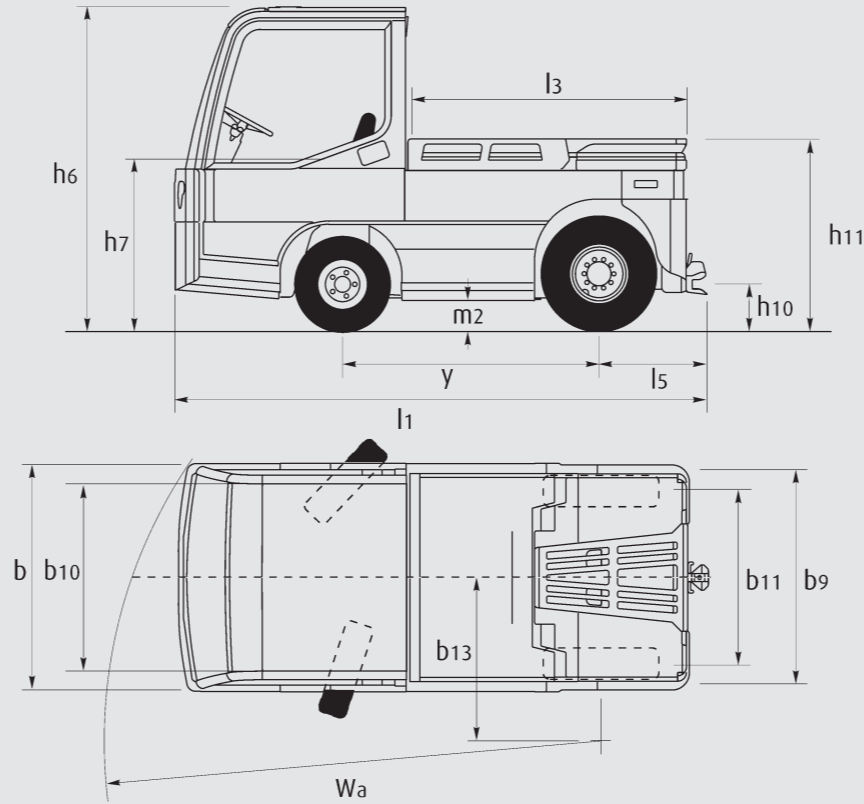

- A = Speed (km/h)
- B = Gradient
- C = Permissible haul per hour (m)
- D = P (N) drawbar pull
- E = Combined weight (trailed plus carried)



Comment on diagram
Load/gradient combination by full line can be raised from stationary on the gradient. The permissible haul per hour is the total distance travelled, including the return journey and any downhill gradients. It is recommended that braked trailers are used for trailer loads exceeding 9 tons and for all trailer loads where a gradient is involved.