



Diesel and LPG Forklift Trucks Capacity 1400 – 2000 kg H 14 – H 20

SERIES 391

Safety

Linde ProtectorFrame: The protective overhead guard and its supporting frame together form a strong and completely enclosed protective zone providing optimum structural integrity, safety and protection for the operator. The top mounted tilt cylinders provide seamless, smooth control of the tilt movements for excellent load stability in all operating conditions. This unique design also enables slimmer mast profiles to be fitted for outstanding visibility.

Performance

Low consumption levels and low exhaust emission and yet this truck still continues to impress with its excellent performance. Advanced engine and drive technology combined with the original Linde Load Control system enables the operator to use the truck's vast potential to maximise productivity. Comfortable and precise fingertip control of all mast functions.

Comfort

Climb on board relaxed, leave again relaxed. Linde brings to this forklift a generously sized automobile-class workspace. Designed to the most advanced ergonomic standards. Spacious cab interior, adjustable armrest, suspension seat and functional positioning of easy-actuation controls allows fast, stress-free working.



Linde Material Handling

Linde

Reliability

Proven in tough sustained operation. Isolation of the cab from the mast, drive axle and chassis results in reduced shock and vibration. Maintenance-free mounting of axles and tilt jacks cuts downtime and operating costs.

Productivity

Effective and cost-efficient at work: The original Linde hydrostatic drive cost does away with gearshift, clutch, differential and drum brakes. As a result, servicing costs are low, truck uptime is high and productivity is enhanced.

Technical data

Characteristics	1.1	Manufacturer		LINDE	LINDE
	1.2	Model designation		H 14D	H 14T
	1.3	Power unit: Battery, diesel, gasoline, LP gas, AC		Diesel	LPG
	1.4	Operation: Manual, pedestrian, rider stand, rider seat, order picker		Seated	Seated
	1.5	Load capacity	Q (t)	1.4	1.4
	1.6	Load center	c (mm)	500	500
	1.8	Load distance	x (mm)	365	365
	1.9	Wheelbase	y (mm)	1500	1500
Weight	2.1	Service weight	kg	2590	2570
	2.2	Axle load with load, front / rear	kg	3490/500	3450/520
	2.3	Axle load without load, front / rear	kg	1280/1310	1240/1330
Wheels and tyres	3.1	Tyres: Solid rubber (R), Superelastic (SE), Pneumatic (P), Polyurethane (PU)		SE	SE
	3.2	Tyre size, front		18x7-8 ¹⁾	18x7-8 ¹⁾
	3.3	Tyre size, rear		18x7-8	18x7-8
	3.5	Wheels, number front / rear (x = driven)		2 x/2	2 x/2
	3.6	Track width, front	b10 (mm)	930	930
	3.7	Track width, rear	b11 (mm)	873	873
	Dimensions	4.1	Mast/fork carriage tilt, forward/back	α/β (°)	6.0/9.0 ²⁾
4.2		Height of mast, lowered	h1 (mm)	2197 ³⁾	2197 ³⁾
4.3		Free lift	h2 (mm)	150	150
4.4		Lift	h3 (mm)	3110	3110
4.5		Height of mast, extended	h4 (mm)	3754	3754
4.7		Height of overhead guard/cab	h6 (mm)	2123	2123
4.8		Height of seat	h7 (mm)	1067	1067
4.12		Height of tow coupling	h10 (mm)	557	557
4.19		Overall length	l1 (mm)	3112	3112
4.20		Length to fork face	l2 (mm)	2212	2212
4.21		Overall width	b1/b2 (mm)	1086	1086
4.22		Fork dimensions	s/e/l (mm)	40x80x900	40x80x900
4.23		Fork carriage to DIN 15173, Class/Form A, B		2A	2A
4.24		Width of fork carriage	b3 (mm)	1040	1040
4.31		Ground clearance under mast, with load	m1 (mm)	94	94
4.32		Ground clearance, center of wheelbase	m2 (mm)	120	120
4.33		Aisle width, 1000 x 1200 mm pallet crosswise	Ast (mm)	3570	3570
4.34		Aisle width, 800 x 1200 mm pallet lengthwise	Ast (mm)	3770	3770
4.35		Turning radius	Wa (mm)	2005	2005
4.36		Minimum pivot point distance	b13 (mm)	600	600
Performance	5.1	Travel speed, with / without load	km/h	20/20	20/20
	5.2	Lift speed, with / without load	m/s	0.6/0.63	0.6/0.63
	5.3	Lower speed, with / without load	m/s	0.57/0.57	0.57/0.57
	5.5	Tractive force, with / without load	N	12900/10050	12900/9700
	5.7	Climbing ability, with / without load	%	35/40	35/39
	5.9	Acceleration, with / without load	s	4.7/4.2	4.7/4.2
	5.10	Service brake		hydrostatic	hydrostatic
IC-engine	7.1	Engine manufacturer/type		VW/BXT	VW/BEF
	7.2	Engine output to ISO 1585	kW	26	28
	7.3	Rated speed	min ⁻¹	2100	2100
	7.4	Number of cylinders/cubic capacity	cm ³	4/1896	4/1984
	7.5	Fuel consumption to VDI cycle	l/h; kg/h	2.2 ⁵⁾	2.0 ⁵⁾
Others	8.1	Traction control		hydr./infinitely variable	hydr./infinitely variable
	8.2	Working pressure for attachments	bar	180	180
	8.3	Oil flow for attachments	l/min	38	38
	8.4	Noise level at driver's ear to EN 12053	dB(A)	75	73
	8.5	Tow coupling, design/type		-	-

All data based on standard equipment with Standardmast 3110 mm

¹⁾ Alternatively SE 18x7-8 or 200/50-10 (SE)

²⁾ Lift height and equipment can alter rear mast tilt angle

³⁾ With 150 mm free lift on standard mast

⁴⁾ When ordering ETB Diesel particulate filter (Filter changing) and LPG bottles (big) for GB, AUS, J

⁵⁾ Figure higher than previous due to amended measuring method in VDI Code 2198

LINDE	LINDE	LINDE	LINDE	LINDE	LINDE
H 16 D	H 16 T	H 18 D	H 18 T	H 20 D	H 20 T
Diesel	LPG	Diesel	LPG	Diesel	LPG
Seated	Seated	Seated	Seated	Seated	Seated
1.6	1.6	1.8	1.8	2.0	2.0
500	500	500	500	500	500
365	365	370	370	374	374
1500 (1600) ⁴⁾	1500 (1600) ⁴⁾	1540 (1600) ⁴⁾	1540 (1600) ⁴⁾	1600	1600
2745 (2795) ⁴⁾	2725 (2775) ⁴⁾	2910	2890	3060	3040
3820/525 (3760/635) ⁴⁾	3780/545 (3720/655) ⁴⁾	4160/550 (4120/590) ⁴⁾	4120/570 (4080/610) ⁴⁾	4480/580	4440/600
1295/1450 (1295/1500) ⁴⁾	1255/1470 (1255/1520) ⁴⁾	1340/1570 (1340/1570) ⁴⁾	1300/1590 (1300/1590) ⁴⁾	1390/1670	1350/1690
SE	SE	SE	SE	SE	SE
18x7-8 ¹⁾	18x7-8 ¹⁾	18x7-8 ¹⁾	18x7-8 ¹⁾	200/50-10	200/50-10
18x7-8	18x7-8	18x7-8	18x7-8	18x7-8	18x7-8
2x/2	2x/2	2x/2	2x/2	2x/2	2x/2
930	930	930	930	945	945
873	873	873	873	873	873
6.0/9.0 ²⁾	6.0/9.0 ²⁾	6.0/9.0 ²⁾	6.0/9.0 ²⁾	6.0/9.0 ²⁾	6.0/9.0 ²⁾
2197 ³⁾	2197 ³⁾	2197 ³⁾	2197 ³⁾	2198 ³⁾	2198 ³⁾
150	150	150	150	150	150
3110	3110	3110	3110	3110	3110
3754	3754	3754	3754	3755	3755
2123	2123	2123	2123	2123	2123
1067	1067	1067	1067	1067	1067
557	557	549	549	530	530
3112 (3222) ⁴⁾	3112 (3222) ⁴⁾	3152 (3227) ⁴⁾	3152 (3227) ⁴⁾	3231	3231
2212 (2322) ⁴⁾	2212 (2322) ⁴⁾	2252 (2327) ⁴⁾	2252 (2327) ⁴⁾	2331	2331
1086	1086	1086	1086	1152	1152
40 x 80 x 900	40 x 80 x 900	45 x 100 x 900	45 x 100 x 900	45 x 100 x 900	45 x 100 x 900
2A	2A	2A	2A	2A	2A
1040	1040	1040	1040	1040	1040
93	93	92	92	95	95
119	119	118	118	121	121
3570 (3686) ⁴⁾	3570 (3686) ⁴⁾	3611 (3691) ⁴⁾	3611 (3691) ⁴⁾	3695	3695
3770 (3886) ⁴⁾	3770 (3886) ⁴⁾	3811 (3891) ⁴⁾	3811 (3891) ⁴⁾	3895	3895
2005 (2121) ⁴⁾	2005 (2121) ⁴⁾	2041 (2121) ⁴⁾	2041 (2121) ⁴⁾	2121	2121
600 (638) ⁴⁾	600 (638) ⁴⁾	615 (638) ⁴⁾	615 (638) ⁴⁾	638	638
20/20	20/20	20/20	20/20	20/20	20/20
0.6/0.63	0.6/0.63	0.6/0.63	0.6/0.63	0.54/0.57	0.54/0.57
0.57/0.57	0.57/0.57	0.57/0.57	0.57/0.57	0.57/0.57	0.57/0.57
12900/10150	12900/9850	12900/10500	12900/10200	12900/10900	12900/10600
32/38	32/37	29/37	29/36	27/36	27/36
4.9/4.3	4.9/4.3	5.0/4.5	5.0/4.5	5.1/4.6	5.1/4.6
hydrostatic	hydrostatic	hydrostatic	hydrostatic	hydrostatic	hydrostatic
VW/BXT	VW/BEF	VW/BXT	VW/BEF	VW/BXT	VW/BEF
26	28	26	28	26	28
2100	2100	2100	2100	2100	2100
4/1896	4/1984	4/1896	4/1984	4/1896	4/1984
2.3 ⁵⁾	2.1 ⁵⁾	2.4 ⁵⁾	2.2 ⁵⁾	2.5 ⁵⁾	2.3 ⁵⁾
hydr./infinitely variable	hydr./infinitely variable	hydr./infinitely variable	hydr./infinitely variable	hydr./infinitely variable	hydr./infinitely variable
170	170	170	170	170	170
38	38	38	38	38	38
75	73	75	73	75	73
-	-	-	-	-	-

Lifting capacity diagrams

H14

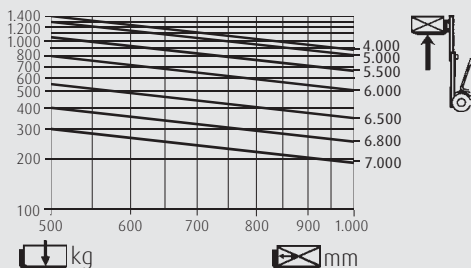

H16

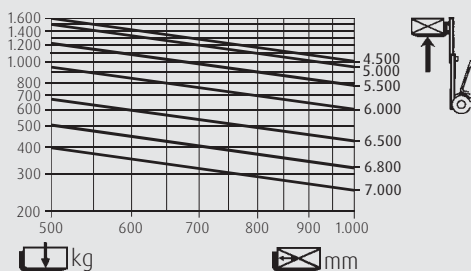

H18

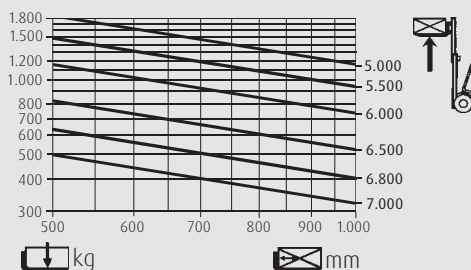

H20

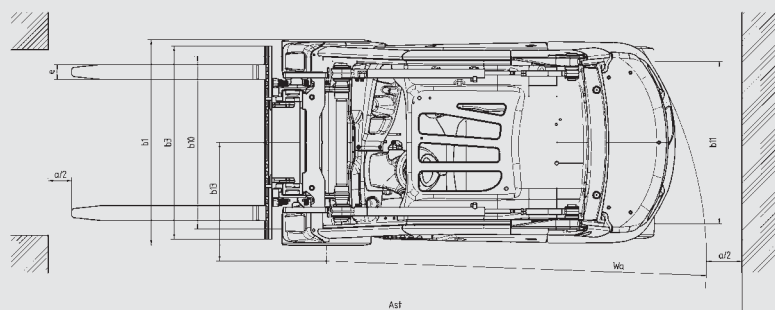
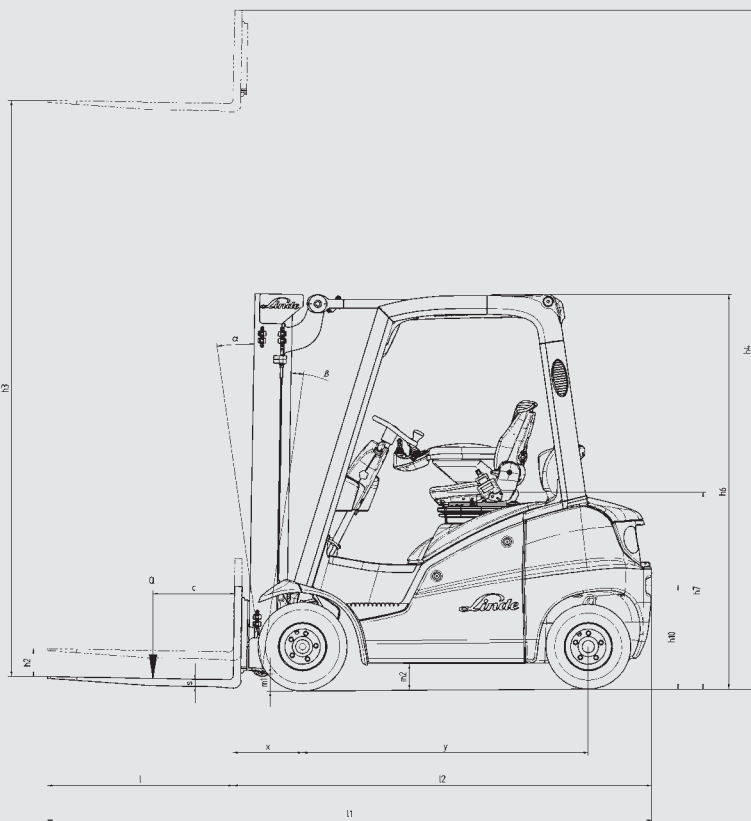
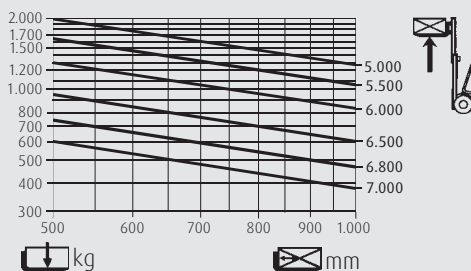

Lifting capacity diagrams are valid for Standard- and Duplexmasts without integrated sideshift with SE-tyres.

Overall height and lift heights, Standard (in mm)		H 14 / H 16 / H 18 / H 20		
Lift	h3	3110	3810	4210
Mast retracted (with 150 mm free lift - standard)	h1#	2196	2546	2746
Mast extended	h4	3713	4413	4813
Special free lift	h2	150	150	150

Overall height and lift heights, Duplex (in mm)		H 14 / H 16 / H 18 / H 20		
Lift	h3	3125	3825	-
Mast retracted	h1	2121	2471	-
Mast extended	h4	3727	4427	-
Special free lift	h2	1518	1868	-

Overall height and lift heights, Triplex (in mm)		H 14 / H 16 / H 18 / H 20		
Lift	h3	4625	5475	-
Mast retracted	h1	2121	2471	-
Mast extended	h4	5227	6077	-
Special free lift	h2	1518	1781	-

Figures for other equipments and triplex masts on request.

Standard and optional equipment

Standard equipment

Truck

Linde twin drive pedals to control forward/reverse travel and braking

Linde Load Control integrated in armrest

Container entry height (overhead guard 2,123 mm)

Hydraulic-suspension comfort-class seat with extensive range of adjustment

Hydrostatic steering with on-demand power assist

High safety and stability ensured by Linde ProtectorFrame

Air intake filter with integral cyclone separator

High-performance hydraulic filter concept, preserves maximum oil purity and extends life of all hydraulic components

Anti-glare display with fuel gauge, clock, hour meter and servicing information

Control lights on display for engine oil pressure, engine overheating, parking brake, audible warning signal for engine and hydraulic oil temperature, blocked intake filter and low fuel level

Plenty of storage space for writing utensils, beverage cans, etc.
Superelastic tyres

LPG truck fitted with two-way catalytic converter and the gas cylinder mount is ergonomically designed for easy changing

LPG volumetric fuel tank version has a fuel level indicator in the display consol

Mast

Standard mast lift height $h_3 = 3,110$ mm

Standard, duplex and triplex masts

Top-mounted tilt jacks

Zero-maintenance mast and tilt jack cylinder mounting

Rubber-mounted joints

Electronic tilt angle limiting

Fork length $l = 900$ mm

Fork carriage width $b_3 = 1,040$ mm

Options

Single drive pedal with direction selector positioned on armrest

Standard masts up to 5,610 mm lift

Duplex masts (full free lift) up to 4,125 mm lift

Triplex masts (full free lift) up to 6,075 mm lift

Integral sideshift

Load backrest

One or two auxiliary hydraulic circuits for all mast types

Alternative fork lengths

Overhead guard can be upgraded to full cabine with roof, front and rear screens and doors (also available with tinted glass)

Wiper-washers for front, rear and roof screens

Seats providing additional comfort and adjustments

Cab heater with integral pollen filter

Air condition with integral pollen filter

Radio with cassette player and speakers

Roof shade, clipboard, interior lighting, height-adjusting steering column

Truck lighting, work lamps

Mirrors

Highway specifications

Integral diesel particulate filter with charge status indicator on the display consol

Air precleaner

Audible reversing alarm, flasher and strobe beacons

Biodiesel (RME) fuel version

LPG truck is fitted with accurate ultrasonic fuel level indicator for exchange cylinders

Custom paintwork

Other options available on request

Features

Original Linde hydrostatic drive

- Responsive, smooth and precise driving
- No clutch, differential or drum brakes; hydrostatic drive assumes function of service brake
- Robust drive system, well proven in severest duty
- Low maintenance costs and long life



Linde ProtectorFrame

- Safe and robust chassis, enclosed on all sides
- Engine hood and servicing doors open wide for convenient access to all components

Linde twin drive pedals

- Quick change of forward/reverse direction without changing feet on pedals
- Short pedal stroke
- No leg fatigue
- Increased productivity

Linde Load Control

- Accurate, safe load handling
- Effortless fingertip control of all mast functions
- Traction and lift functions completely separate

High-economy engine technology

- Diesel and LPG engines incorporating most advanced technology
- High torque
- Low fuel consumption
- Low exhaust gas and soot emission levels



Linde operator compartment

- Designed to advanced ergonomic standards
- Spacious cab with automobile-equivalent legroom
- Excellent visibility of load and surroundings due to slim-line mast sections
- Cushioned drive axle reduces road shock
- Minimum driving noise

Linde Truck Control

- Reliable electronic controller
- Easily matched to individual requirements
- High dependability resulting from redundant monitoring systems
- Automatic control of engine speed as function of load
- Casing totally enclosed for protection from dust and dirt

Linde clear-view mast

- Superb visibility through slim-profile sections of mast
- Full load capacity up to maximum lift height
- Exceptional residual capacity
- Zero-maintenance rubber mounting of mast and tilt jacks
- Electronic limiting of tilt angle

